

F150 Series	Class 150	WCB	TFM Seat
FIRE SAFE API 607-7			Size 2 1/2"-4"

DS-F150-CS-F-G-G-N-L

Size	A	B	C	C1	D	F	N	S	T	d	G	H	K	L	M	P	W	ISO
2 1/2"	7.50	2.56	6.22	3.35	15.4	7.00	4	5.50	0.75	4.02	2.84	2.84	1.75	3.07	0.669	1.10	1/2-13UNC	F10
3"	8.00	3.00	6.54	3.62	15.4	7.50	4	6.00	0.75	4.02	2.84	2.84	1.75	3.07	0.669	1.10	1/2-13UNC	F10
4"	9.00	4.00	7.20	4.35	15.4	9.00	8	7.50	0.75	4.02	2.84	2.84	1.75	3.07	0.669	1.10	1/2-13UNC	F10

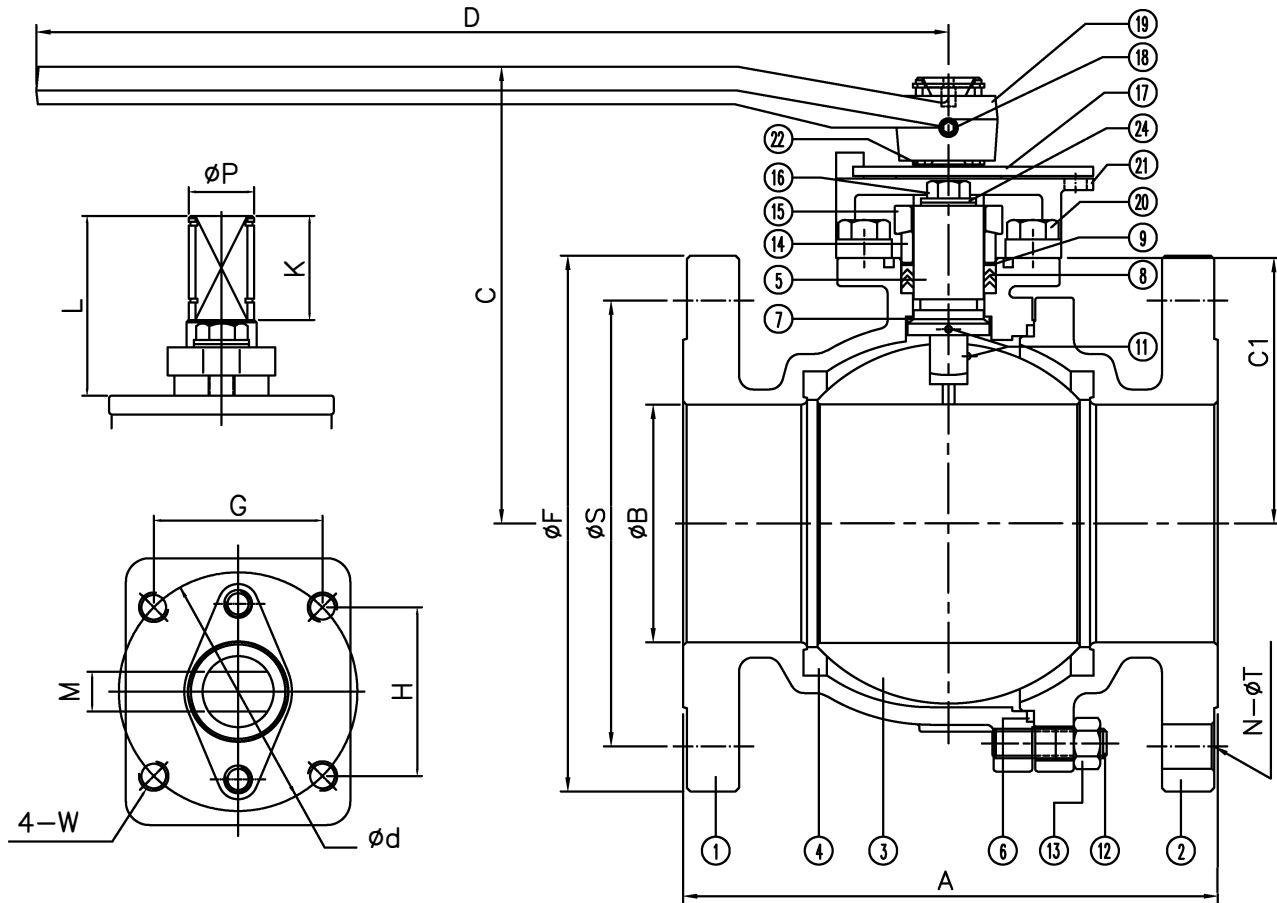

No.	Name	Carbon Steel
1	Body	ASTM A216 WCB
2	Cap	ASTM A216 WCB
3	Ball	ASTM A351 CF8M
4	Seat	TFM
5	Stem	SS316
6	Gasket	SWG SS316/Graphite
7	Thrust Washer	25%Carbon+TFM
8	Stem Packing	Graphite
9	Packing Protector	50%PTFE+SS316
11	Anti-Static	SS316
12	Body Stud	ASTM A193 B7
13	Body Nut	ASTM A194 2H
14	Packing Follower	Steel
15	Packing Gland	17-4Ph
16	Gland Bolt	Steel
17	Travel Stopper	Steel
18	Set Screw	Steel
19	Handle	Ductile Iron
20	Housing Bolt	Steel
21	Stop Housing	ASTM A216 WCB
22	Snap Ring	Plated Steel
24	Belleville Washer	SS301

ANSI RATING CLASS 150	
SEAT TEST ● 80-100 PSI	ASME B16.34
SHELL TEST ● 450 PSI	ASME B16.34
PRESSURE TEMPERATURE RATING	ASME B16.34
FACE TO FACE DIMENSION	ASME B16.10
END CONNECTION	ASME B16.5
JOINT STRENGTH	ASME B16.34
WALL THICKNESS	ASME B16.34
BASIC DESIGN	ASME B16.34

For certified drawing, consult factory

Drawn by:	Date:	Scale: NTS	Rev: 0	Drawing Title: Flange Ball Valve Class 150 2 1/2" - 4"
Checked by:	Date:	Unit: inch	Sheet: xxx	Drawing No.: DS-F150CSFGGN-L-02-HC
Approved by:	Date:	Material: See Notes		

FLO TITE™

4815 W. 5th Street
Lumberton, NC 28358
Website: www.flotite.com
Tel.: 910-738-8904
Fax: 910-738-9112
E-mail: flotite@flotite.com

REVIEW ALL STANDARD SOFT PARTS FOR APPLICATION COMPATIBILITY