

F150 Series | Class 150 | WCB | TFM Seat
 FIRE SAFE API 607-7 | Size 2 1/2" - 4"

DS-F150-CS-F-G-G-N-L

Size	A	B	C	C1	D	F	N	S	T	d	G	H	K	L	M	P	W	ISO
2 1/2"	7.50	2.56	6.22	3.39	15.4	7.00	4	5.50	0.75	4.02	2.84	2.84	1.75	3.07	0.669	1.10	1/2-13UNC	F10
3"	8.00	3.00	6.54	3.72	15.4	7.50	4	6.00	0.75	4.02	2.84	2.84	2.36	3.07	0.669	1.10	1/2-13UNC	F10
4"	9.00	4.00	7.20	4.31	15.4	9.00	8	7.50	0.75	4.02	2.84	2.84	2.28	3.07	0.669	1.10	1/2-13UNC	F10

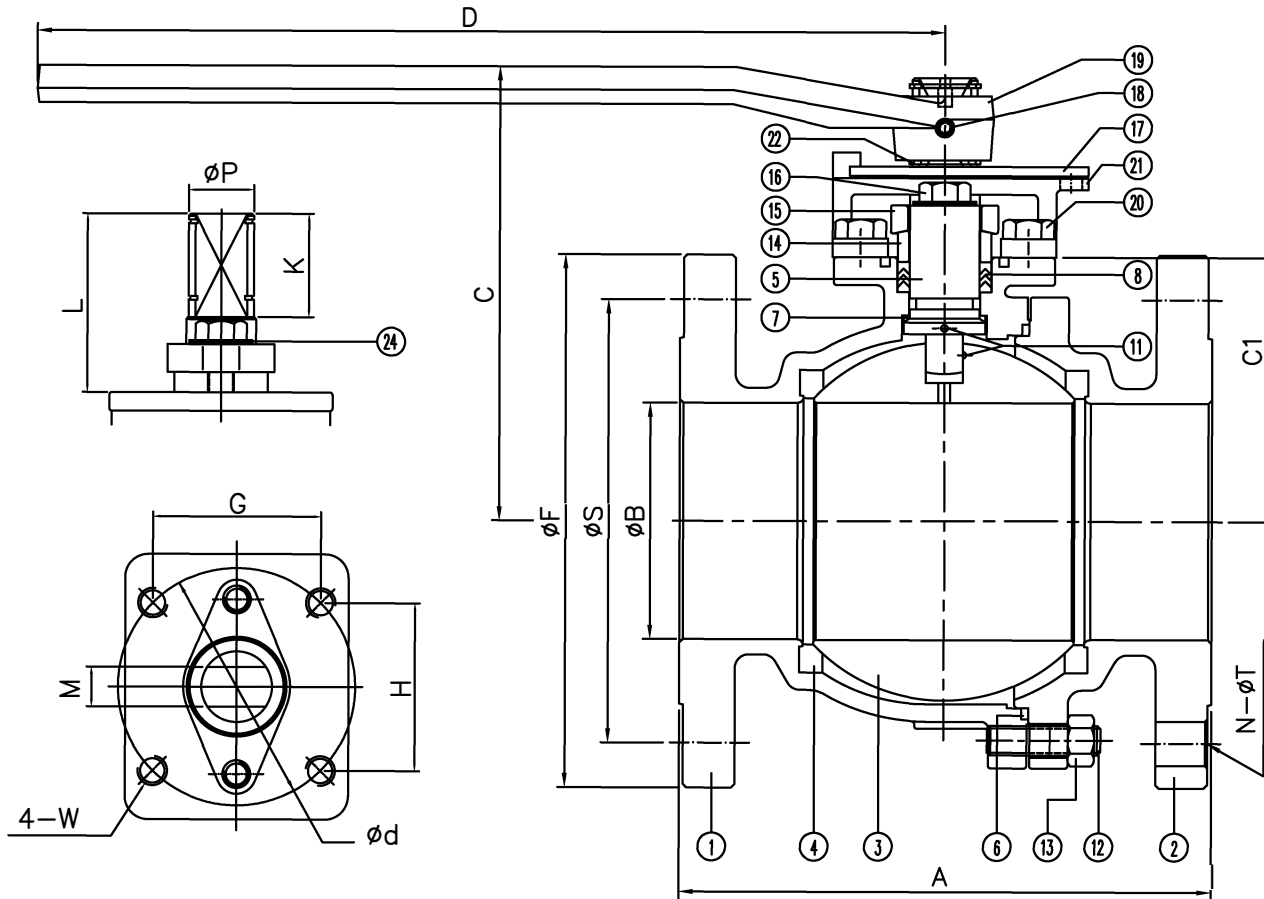

No.	Name	Carbon Steel
1	Body	ASTM A216 WCB
2	Cap	ASTM A216 WCB
3	Ball	ASTM A351 CF8
4	Seat	TFM
5	Stem	SS316
6	Gasket	SWG SS304/Graphite
7	Thrust Washer	25%Carbon+TFM
8	Stem Packing	Graphite
9		
10		
11	Anti-Static	SS304
12	Body Stud	ASTM A193 B7
13	Body Nut	ASTM A194 2H
14	Packing Follower	SS304
15	Packing Gland	ASTM A351 CF8
16	Gland Bolt	Steel
17	Travel Stopper	Steel
18	Set Screw	Steel
19	Handle	Ductile Iron
20	Housing Bolt	Steel
21	Stop Housing	ASTM A351 CF8
22	Snap Ring	Plated Steel
23		
24	Belleville Washer	SS420

ANSI RATING CLASS 150	
SEAT TEST @ 60-100 PSI	ASME B16.34
SHELL TEST @ 450 PSI	ASME B16.34
PRESSURE TEMPERATURE RATING	ASME B16.34
FACE TO FACE DIMENSION	ASME B16.10
END CONNECTION	ASME B16.5
JOINT STRENGTH	ASME B16.34
WALL THICKNESS	ASME B16.34
BASIC DESIGN	ASME B16.34

For certified drawing, consult factory

Drawn by:	Date:	Scale: NTS	Rev: 0	Drawing Title: Flange Ball Valve Class 150 2 1/2" - 4"
Checked by:	Date:	Unit: inch	Sheet: xxx	
Approved by:	Date:	Material: See Notes		
Drawing No.: DS-F150CSFGGN-L-02-YM				

FLO TITE™

4815 W. 5th Street
 Lumberton, NC 28358
 Website: www.flotite.com
 Tel: 910-738-8904
 Fax: 910-738-9112
 E-mail: flotite@flotite.com

REVIEW ALL STANDARD SOFT PARTS FOR APPLICATION COMPATIBILITY