

Super-Tek Seat
CS
T23-CS-F-F-G-L-???
2000 WOG
NON FIRESAFE PER API 607-5
Fusion Series

SIZE		ØD		ØG		H		h		l		ØJ		K		L		M	P		W		FO
inch	mm	inch	mm	inch	mm	inch	mm	inch	mm	inch	mm	inch	mm	inch	mm	inch	mm		inch	mm	inch	mm	
1/4"	8	0.43	11	1.42	36	2.17	55	0.94	24	0.20	5	0.31	8	0.35	9	2.32	59	M5	0.57	14.50	5.31	135	F04
3/8"	10	0.49	12.50	1.42	36	2.17	55	0.94	24	0.20	5	0.31	8	0.35	9	2.32	59	M5	0.57	14.50	5.31	135	F04
1/2"	15	0.59	15	1.42	36	2.24	57	1.02	26	0.20	5	0.31	8	0.45	11.50	2.52	64	M5	0.69	17.50	5.31	135	F04
3/4"	20	0.79	20	1.42	36	2.50	63.50	1.28	32.50	0.24	6	0.39	10	0.55	14	2.87	73	M5	0.79	20	5.31	135	F04
1"	25	0.98	25	1.65	42	2.66	67.50	1.42	36	0.31	8	0.47	12	0.65	16.50	3.35	85	M5	0.91	23	6.50	165	F05
1 1/4"	32	1.26	32	1.65	42	2.87	73	1.63	41.50	0.31	8	0.47	12	0.65	16.50	3.94	100	M5	0.91	23	6.50	165	F05
1 1/2"	40	1.50	38	1.97	50	3.56	90.50	2.01	51.15	0.31	8	0.55	14	0.79	20	4.53	115	M6	1.06	27	6.89	175	F07
2"	50	1.97	50	1.97	50	4.17	106	2.56	65	0.39	10	0.55	14	0.79	20	5.28	134	M6	1.06	27	9.65	245	F07
2-1/2"	65	2.56	65	2.76	70	5.06	128.50	3.15	80	0.47	12	0.79	20	1.14	29	6.54	166	M8	1.56	39.50	12.60	320	F10
3"	80	3.15	80	2.76	70	5.49	139.50	3.58	91	0.47	12	0.79	20	1.14	29	7.44	189	M8	1.56	39.50	12.60	320	F10
4"	100	3.94	100	4.02	102	6.50	165	4.41	112	0.63	16	0.98	25	1.48	37.50	9.09	231	M10	2.07	52.50	10.80	274	F12

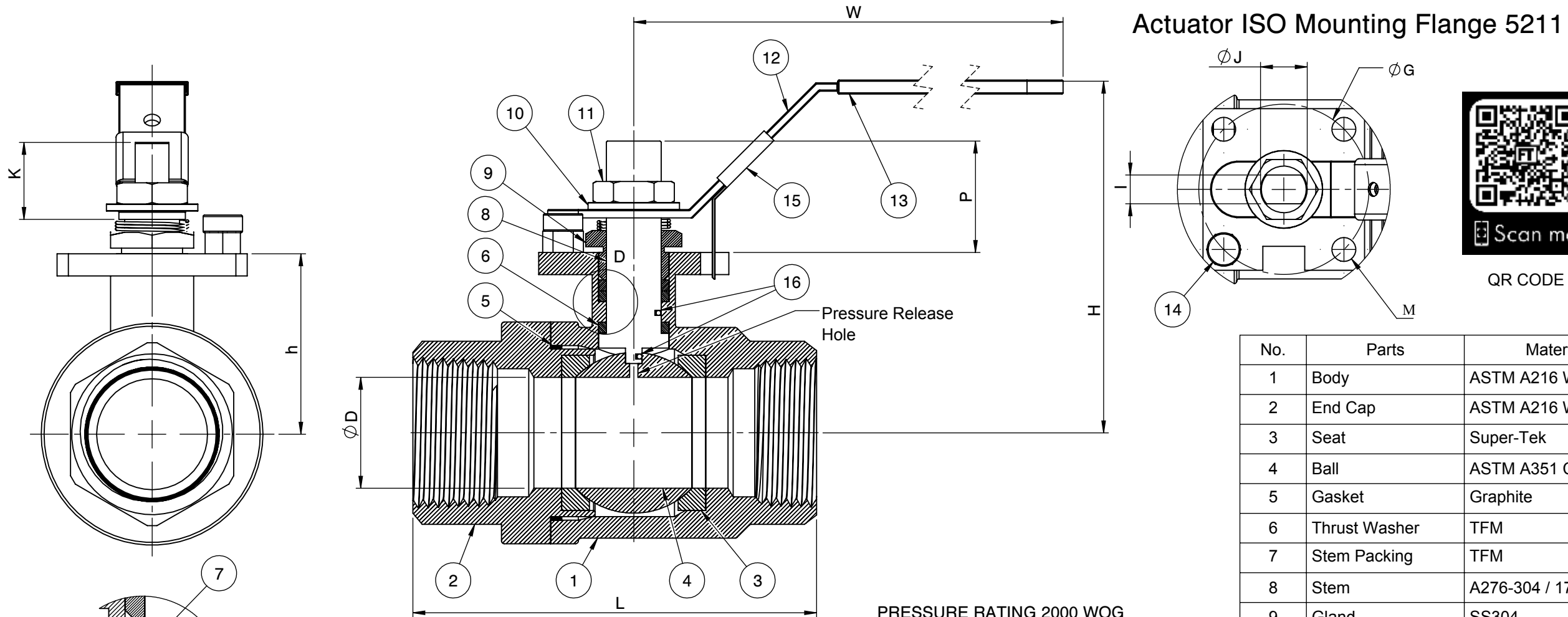

Actuator ISO Mounting Flange 5211

No.	Parts	Material
1	Body	ASTM A216 WCB
2	End Cap	ASTM A216 WCB
3	Seat	Super-Tek
4	Ball	ASTM A351 CF8
5	Gasket	Graphite
6	Thrust Washer	TFM
7	Stem Packing	TFM
8	Stem	A276-304 / 17-4PH
9	Gland	SS304
10	Handle Washer	SS304
11	Handle Nut	SS304
12	Handle	Zinc Plated Steel
13	Handle Cover	PVC
14	Stop Screw	Steel
15	Locking Device	Zinc Plated CS
16	Anti-Static Device	SS304

SEAT TEST @ 80~100 PSI	ASME B16.34
SHELL TEST @ 2175 PSI	ASME B16.34
PRESSURE TEMPERATURE RATING	ASME B16.34
END CONNECTION	ASME B16.11
JOINT STRENGTH	ASME B16.34
WALL THICKNESS	ASME B16.34
BASIC DESIGN	ASME B16.34

FOR CERTIFIED DRAWING CONSULT FACTORY	Drawn by : M	Date : June 14, 2019	Scale : Not To Scale	Rev : 0	Drawing Title: NPT - FULL PORT BALL VALVE Drawing No.: DS-T23CSFFGL???		4815 W. 5th Street Lumberton, NC 28358 Website: www.flotite.com	Tel : 910-738-8904 Fax : 910-738-9112 E-mail : flotite@flotite.com
	Checked by : M	Date : June 14, 2019	Unit : Inch	Sheet : xxx				
	Approved by : M	Date : June 14, 2019	Material : See Notes					

REVIEW ALL STANDARD SOFT PARTS FOR APPLICATION COMPATIBILITY