

Super-Tek Seat
CS
2000 WOG
Fusion Series

T23-CS-F-F-G-L-??-XS?
NON FIRESAFE PER API 607-5

| SIZE | | Ø D | | W | | d | | Ø G | | H | | C | | I | | Ø J | | K | | A | | M | P | | FO |
|--------|----|------|-------|------|-----|------|-------|------|----|------|--------|------|-------|------|----|------|----|------|-------|------|-----|----|------|-------|-----|
| inch | mm | inch | mm | inch | mm | inch | mm | inch | mm | inch | mm | inch | mm | inch | mm | inch | mm | inch | mm | inch | mm | | inch | mm | |
| 1/4" | 8 | 0.43 | 11 | 5.31 | 135 | 3.00 | 76.20 | 1.42 | 36 | 5.16 | 131.06 | 0.94 | 24 | 0.20 | 5 | 0.31 | 8 | 0.35 | 9 | 2.32 | 59 | M5 | 0.57 | 14.50 | F04 |
| 3/8" | 10 | 0.49 | 12.50 | 5.31 | 135 | 3.00 | 76.20 | 1.42 | 36 | 5.16 | 131.06 | 0.94 | 24 | 0.20 | 5 | 0.31 | 8 | 0.35 | 9 | 2.32 | 59 | M5 | 0.57 | 14.50 | F04 |
| 1/2" | 15 | 0.59 | 15 | 5.31 | 135 | 3.00 | 76.20 | 1.42 | 36 | 5.28 | 134.11 | 1.06 | 26 | 0.20 | 5 | 0.31 | 8 | 0.45 | 11.50 | 2.52 | 64 | M5 | 0.69 | 17.50 | F04 |
| 3/4" | 20 | 0.79 | 20 | 5.31 | 135 | 3.00 | 76.20 | 1.42 | 36 | 5.49 | 139.45 | 1.28 | 32.50 | 0.24 | 6 | 0.39 | 10 | 0.55 | 14 | 2.87 | 73 | M5 | 0.79 | 20 | F04 |
| 1" | 25 | 0.98 | 25 | 6.50 | 165 | 3.00 | 76.20 | 1.65 | 42 | 5.79 | 147.06 | 1.52 | 38.60 | 0.31 | 8 | 0.47 | 12 | 0.65 | 16.50 | 3.35 | 85 | M5 | 0.91 | 23 | F05 |
| 1 1/4" | 32 | 1.26 | 32 | 6.50 | 165 | 3.00 | 76.20 | 1.65 | 42 | 5.91 | 150.11 | 1.63 | 41.50 | 0.31 | 8 | 0.47 | 12 | 0.65 | 16.50 | 3.94 | 100 | M5 | 0.91 | 23 | F05 |
| 1 1/2" | 40 | 1.50 | 38 | 9.65 | 245 | 3.00 | 76.20 | 1.97 | 50 | 6.54 | 166.11 | 2.01 | 51.15 | 0.31 | 8 | 0.55 | 14 | 0.79 | 20 | 4.53 | 115 | M6 | 1.06 | 27 | F07 |
| 2" | 50 | 1.97 | 50 | 9.65 | 245 | 3.00 | 76.20 | 1.97 | 50 | 7.09 | 180.08 | 2.56 | 65 | 0.39 | 10 | 0.55 | 14 | 0.79 | 20 | 5.28 | 134 | M6 | 1.06 | 27 | F07 |

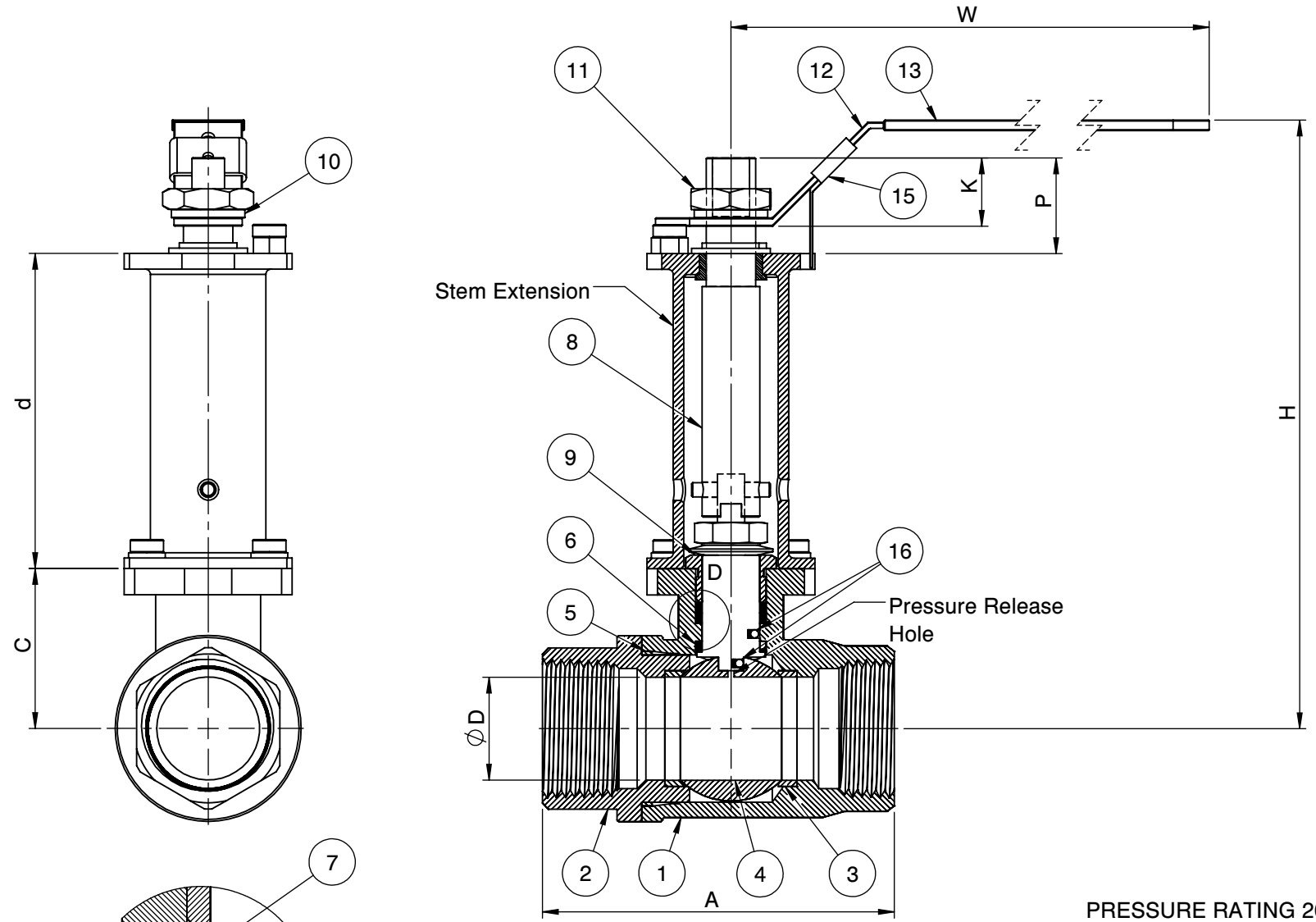

Actuator ISO Mounting Flange 5211

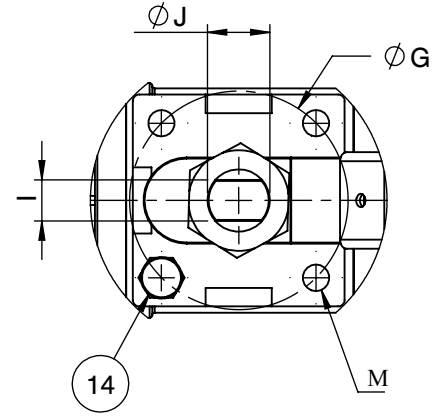

QR CODE

| No. | Parts | Material |
|-----|--------------------|-------------------|
| 1 | Body | ASTM A216 WCB |
| 2 | End Cap | ASTM A216 WCB |
| 3 | Seat | Super-Tek |
| 4 | Ball | ASTM A351 CF8 |
| 5 | Gasket | Graphite |
| 6 | Thrust Washer | TFM |
| 7 | Stem Packing | TFM |
| 8 | Stem | A276-304 / 17-4PH |
| 9 | Gland | SS304 |
| 10 | Handle Washer | SS304 |
| 11 | Handle Nut | SS304 |
| 12 | Handle | Zinc Plated Steel |
| 13 | Handle Cover | PVC |
| 14 | Stop Screw | Steel |
| 15 | Locking Device | Zinc Plated CS |
| 16 | Anti-Static Device | SS304 |

PRESSURE RATING 2000 WOG

| | |
|-----------------------------|-------------|
| SEAT TEST @ 80~100 PSI | ASME B16.34 |
| SHELL TEST @ 2175 PSI | ASME B16.34 |
| PRESSURE TEMPERATURE RATING | ASME B16.34 |
| END CONNECTION | ASME B16.11 |
| JOINT STRENGTH | ASME B16.34 |
| WALL THICKNESS | ASME B16.34 |
| BASIC DESIGN | ASME B16.34 |

DETAIL D

FOR CERTIFIED DRAWING CONSULT FACTORY

| | | | | | | | |
|---------------|---|--------|---------------|------------|--------------|---------|-----|
| Drawn by : | M | Date : | June 17, 2019 | Scale : | Not To Scale | Rev : | 0 |
| Checked by : | M | Date : | June 17, 2019 | Unit : | Inch | Sheet : | xxx |
| Approved by : | M | Date : | June 17, 2019 | Material : | See Notes | | |

| | |
|----------------|----------------------------|
| Drawing Title: | NPT - FULL PORT BALL VALVE |
| Drawing No.: | DS-T23CSFFGL??-XS? |



4815 W. 5th Street
Lumberton, NC 28358
Website: www.flotite.com
Tel : 910-738-8904
Fax : 910-738-9112
E-mail : flotite@flotite.com

REVIEW ALL STANDARD SOFT PARTS FOR APPLICATION COMPATIBILITY