

Super-Tek Seat
SS
T23-SS-F-F-G-L-???
2000 WOG
NON FIRESAFE PER API 607-5
Fusion Series

SIZE		ØD		ØG		H		h		l		ØJ		K		L		M	P		W		FO
inch	mm	inch	mm	inch	mm	inch	mm	inch	mm	inch	mm	inch	mm	inch	mm	inch	mm		inch	mm	inch	mm	
1/4"	8	0.43	11	1.42	36	2.17	55	0.94	24	0.20	5	0.31	8	0.35	9	2.32	59	M5	0.57	14.50	5.31	135	F04
3/8"	10	0.49	12.50	1.42	36	2.17	55	0.94	24	0.20	5	0.31	8	0.35	9	2.32	59	M5	0.57	14.50	5.31	135	F04
1/2"	15	0.59	15	1.42	36	2.24	57	1.02	26	0.20	5	0.31	8	0.45	11.50	2.52	64	M5	0.69	17.50	5.31	135	F04
3/4"	20	0.79	20	1.42	36	2.50	63.50	1.28	32.50	0.24	6	0.39	10	0.55	14	2.87	73	M5	0.79	20	5.31	135	F04
1"	25	0.98	25	1.65	42	2.66	67.50	1.42	36	0.31	8	0.47	12	0.65	16.50	3.35	85	M5	0.91	23	6.50	165	F05
1 1/4"	32	1.26	32	1.65	42	2.87	73	1.63	41.50	0.31	8	0.47	12	0.65	16.50	3.94	100	M5	0.91	23	6.50	165	F05
1 1/2"	40	1.50	38	1.97	50	3.56	90.50	2.01	51.15	0.31	8	0.55	14	0.79	20	4.53	115	M6	1.06	27	6.89	175	F07
2"	50	1.97	50	1.97	50	4.17	106	2.56	65	0.39	10	0.55	14	0.79	20	5.28	134	M6	1.06	27	9.65	245	F07
2-1/2"	65	2.56	65	2.76	70	5.06	128.50	3.15	80	0.47	12	0.79	20	1.14	29	6.54	166	M8	1.56	39.50	12.60	320	F10
3"	80	3.15	80	2.76	70	5.49	139.50	3.58	91	0.47	12	0.79	20	1.14	29	7.44	189	M8	1.56	39.50	12.60	320	F10
4"	100	3.94	100	4.02	102	6.50	165	4.41	112	0.63	16	0.98	25	1.48	37.50	9.09	231	M10	2.07	52.50	10.80	274	F12

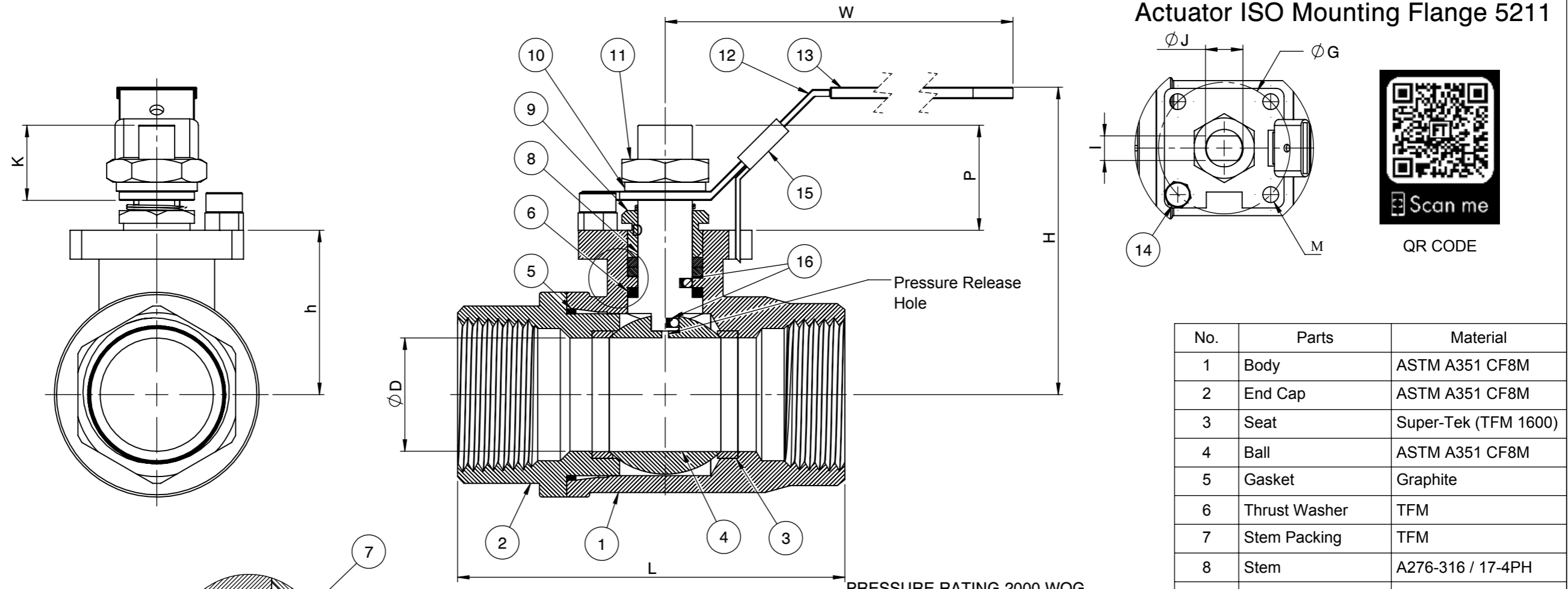

Actuator ISO Mounting Flange 5211

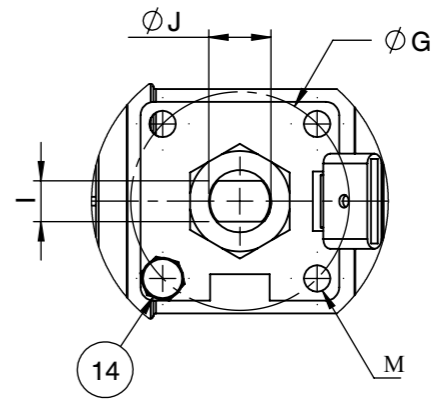

QR CODE

No.	Parts	Material
1	Body	ASTM A351 CF8M
2	End Cap	ASTM A351 CF8M
3	Seat	Super-Tek (TFM 1600)
4	Ball	ASTM A351 CF8M
5	Gasket	Graphite
6	Thrust Washer	TFM
7	Stem Packing	TFM
8	Stem	A276-316 / 17-4PH
9	Gland	SS304
10	Handle Washer	SS304
11	Handle Nut	SS304
12	Handle	SS304
13	Handle Cover	PVC
14	Stop Screw	SS304
15	Locking Device	SS304
16	Anti-Static Device	SS316

SEAT TEST @ 80~100 PSI	ASME B16.34
SHELL TEST @ 2175 PSI	ASME B16.34
PRESSURE TEMPERATURE RATING	ASME B16.34
END CONNECTION	ASME B16.11
JOINT STRENGTH	ASME B16.34
WALL THICKNESS	ASME B16.34
BASIC DESIGN	ASME B16.34

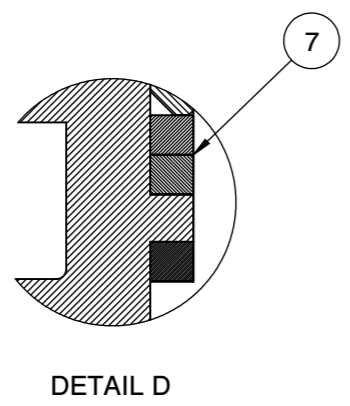

DETAIL D

FOR CERTIFIED DRAWING CONSULT FACTORY

Drawn by :	M	Date :	June 17, 2019	Scale :	Not To Scale	Rev :	0
Checked by :	M	Date :	June 17, 2019	Unit :	Inch	Sheet :	xxx
Approved by :	M	Date :	June 17, 2019	Material :	See Notes		

Drawing Title:	NPT - FULL PORT BALL VALVE
Drawing No.:	DS-T23SSFFGL???

FLO TITE™
 4815 W. 5th Street
 Lumberton, NC 28358
 Website: www.flotite.com
 Tel : 910-738-8904
 Fax : 910-738-9112
 E-mail : flotite@flotite.com

REVIEW ALL STANDARD SOFT PARTS FOR APPLICATION COMPATIBILITY