

**Fusion Series 2000 WOG CS Super-Tek III Seat**

**S23-CS-F-G-G-O-050**

**FIRESAFE PER API 607-5**

**SIZE 2"**

Actuator ISO Mounting Flange (F07)

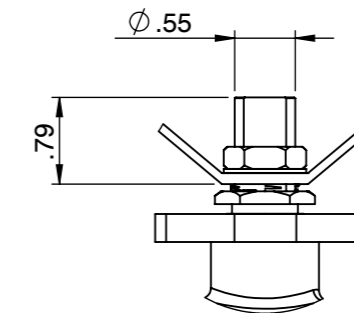
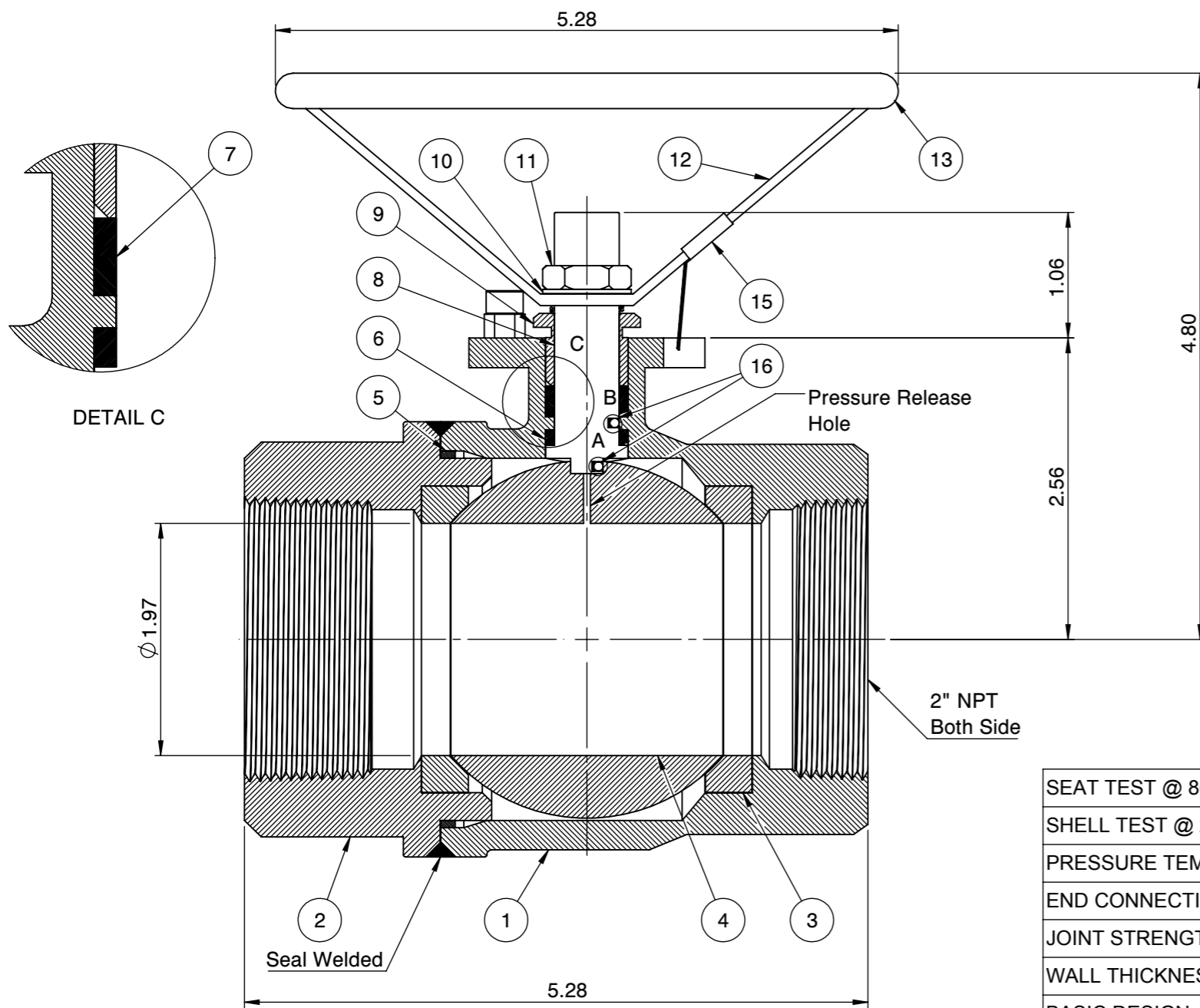
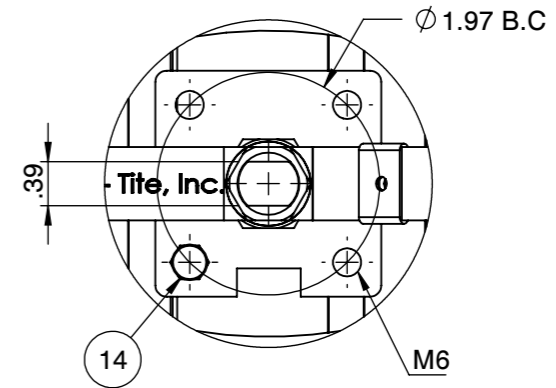
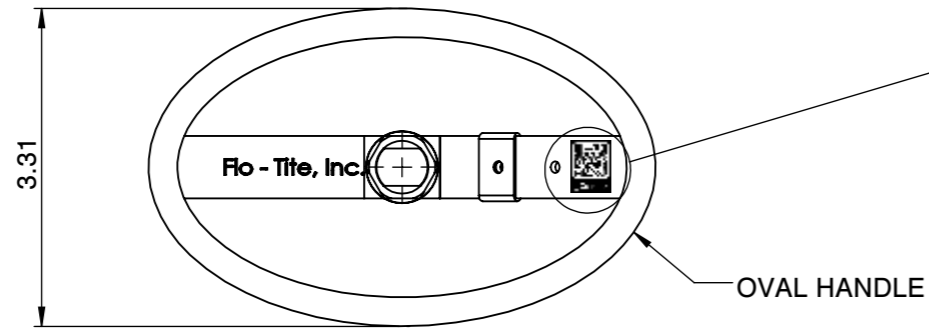

CS: Flo-Tite S23CS

WCB 2000 WOG

1-1/4" - 2" Body marking

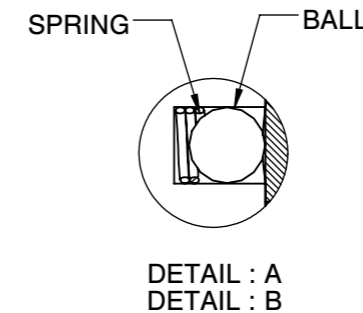

No.	Parts	Material
1	Body	ASTM A216 WCB
2	End Cap	ASTM A216 WCB
3	Seat	Super-Tek III
4	Ball	ASTM A351 CF8
5	Gasket	Graphite
6	Thrust Washer	25% Carbon PTFE
7	Stem Packing	Graphite
8	Stem	A276-304 / 17-4PH
9	Gland	SS304
10	Handle Washer	SS304
11	Handle Nut	SS304
12	Handle	Zinc Plated Steel
13	Handle Cover	PVC
14	Stop Screw	Steel
15	Locking Device	Zinc Plated CS
16	Anti-Static Device	SS304

PRESSURE RATING 2000 WOG

SEAT TEST @ 80~100 PSI	ASME B16.34
SHELL TEST @ 2175 PSI	ASME B16.34
PRESSURE TEMPERATURE RATING	ASME B16.34
END CONNECTION	ASME B16.11
JOINT STRENGTH	ASME B16.34
WALL THICKNESS	ASME B16.34
BASIC DESIGN	ASME B16.34

FOR CERTIFIED DRAWING CONSULT FACTORY

Drawn by : M Date : June 24, 2019 Scale : Not To Scale Rev : 0  
 Checked by : M Date : June 24, 2019 Unit : Inch Sheet : xxx  
 Approved by : M Date : June 24, 2019 Material : See Notes

Drawing Title: NPT 2" FULL PORT BALL VALVE  
 Drawing No.: DT-S23CSFGGO050

**FLO-TITE™**

4815 W. 5th Street Tel : 910-738-8904  
 Lumberton, NC 28358 Fax : 910-738-9112  
 Website: www.flotite.com E-mail : flotite@flotite.com

REVIEW ALL STANDARD SOFT PARTS FOR APPLICATION COMPATIBILITY