

Fusion Series **2000 WOG** **SS** **Super-Tek Seat**
NON FIRESAFE PER API 607-5 **SIZE 3/8"**

T23-SS-F-F-G-L-010

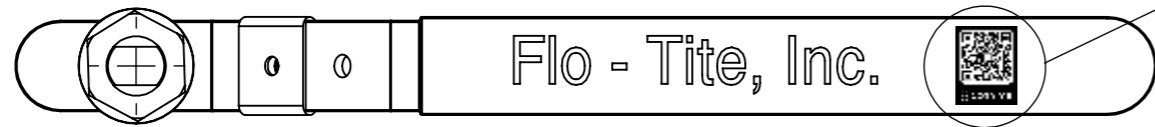

Actuator ISO Mounting Flange (F04)

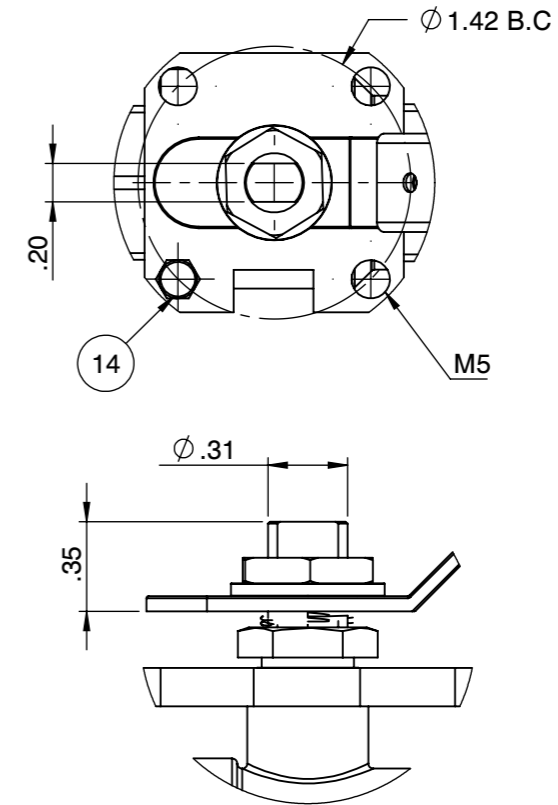

SS: Flo-Tite T23SS CF8M 3/8" 2000 WOG
 1/4" - 1" Body marking

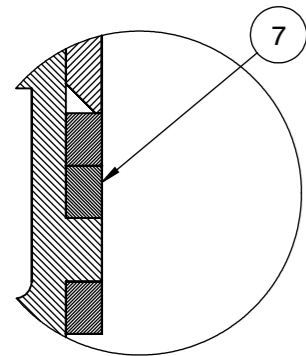

DETAIL C

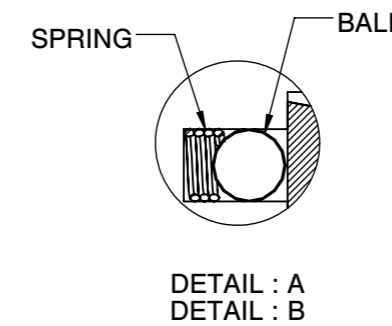
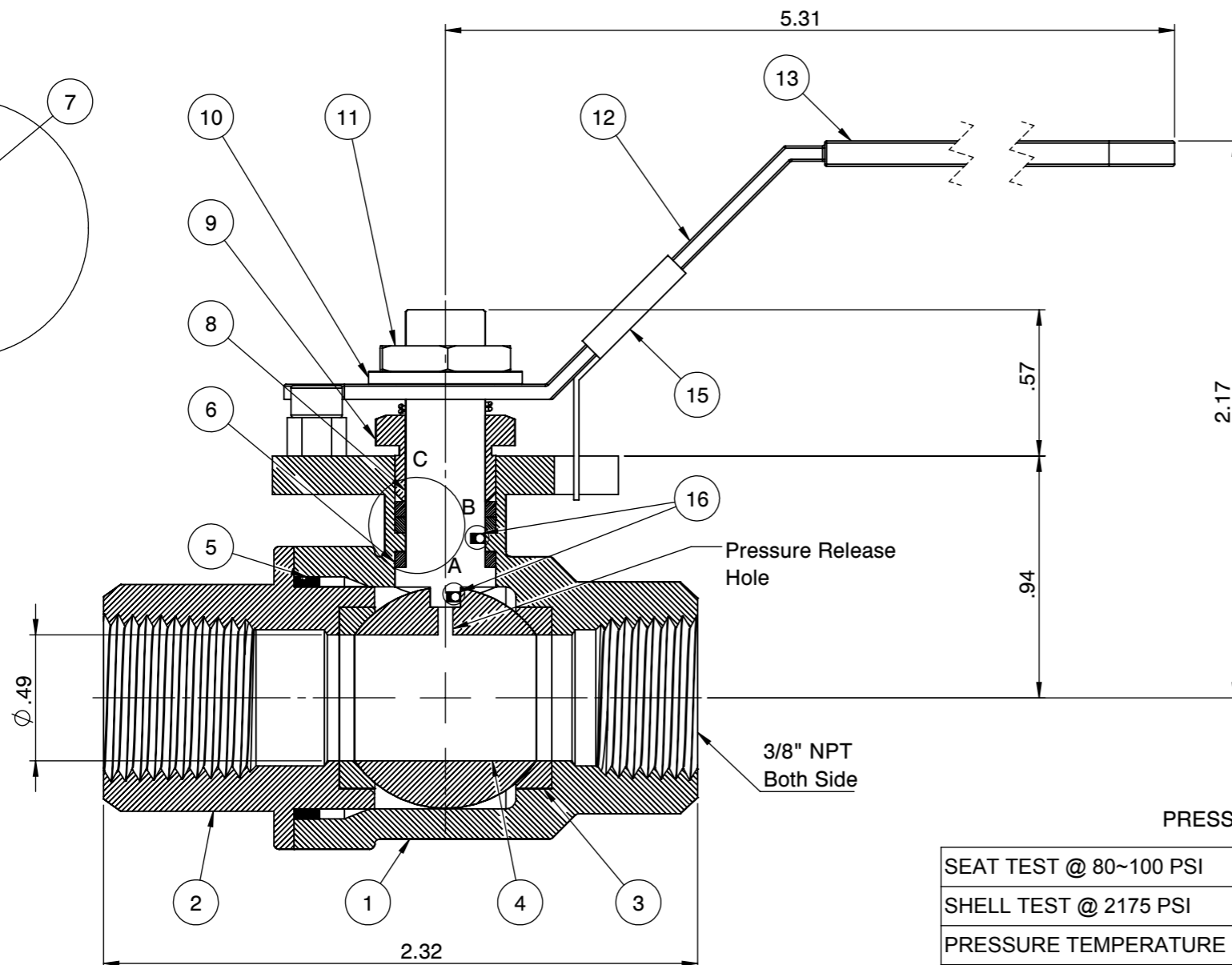

DETAIL : A
 DETAIL : B

No.	Parts	Material
1	Body	ASTM A351 CF8M
2	End Cap	ASTM A351 CF8M
3	Seat	Super-Tek (TFM 1600)
4	Ball	ASTM A351 CF8M
5	Gasket	Graphite
6	Thrust Washer	TFM
7	Stem Packing	TFM
8	Stem	A276-316 / 17-4PH
9	Gland	SS304
10	Handle Washer	SS304
11	Handle Nut	SS304
12	Handle	SS304
13	Handle Cover	PVC
14	Stop Screw	SS304
15	Locking Device	SS304
16	Anti-Static Device	SS316

PRESSURE RATING 2000 WOG

SEAT TEST @ 80~100 PSI	ASME B16.34
SHELL TEST @ 2175 PSI	ASME B16.34
PRESSURE TEMPERATURE RATING	ASME B16.34
END CONNECTION	ASME B16.11
JOINT STRENGTH	ASME B16.34
WALL THICKNESS	ASME B16.34
BASIC DESIGN	ASME B16.34

FOR CERTIFIED DRAWING CONSULT FACTORY	Drawn by : M	Date : June 21, 2019	Scale : Not To Scale	Rev : 0	Drawing Title: NPT 3/8" FULL PORT BALL VALVE Drawing No.: DT-T23SSFFGL010	4815 W. 5th Street Tel : 910-738-8904 Lumberton, NC 28358 Fax : 910-738-9112 Website: www.flotite.com E-mail : flotite@flotite.com
	Checked by : M	Date : June 21, 2019	Unit : Inch	Sheet : xxx		
	Approved by : M	Date : June 21, 2019	Material : See Notes			

REVIEW ALL STANDARD SOFT PARTS FOR APPLICATION COMPATIBILITY