

Fusion Series **2000 WOG** **SS** **Super-Tek Seat**
NON FIRESAFE PER API 607-5 **SIZE 1"**

T23-SS-F-F-G-L-025-XS3

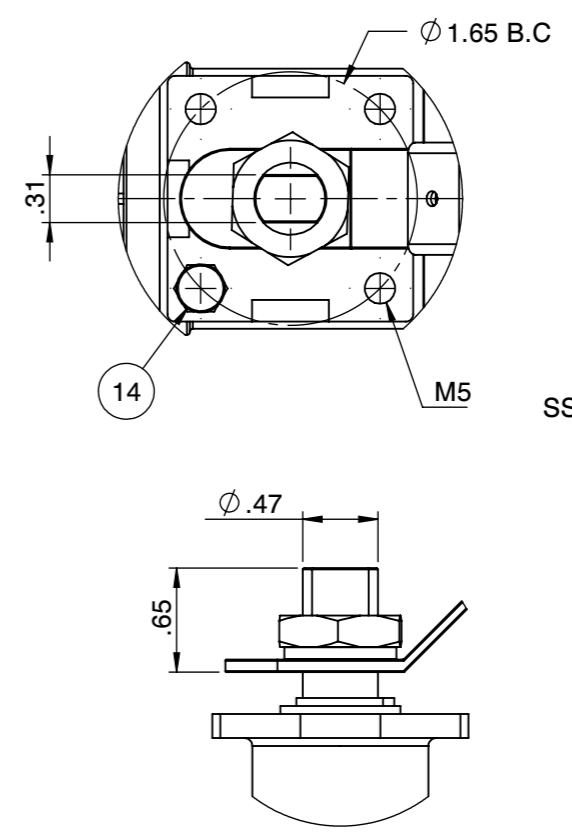

Actuator ISO Mounting Flange (F05)



SS: Flo-Tite
T23SS
CF8M

1"
2000
WOG

1/4" - 1" Body marking

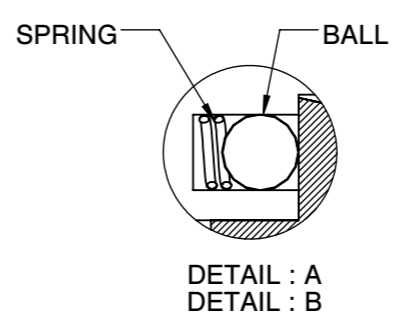
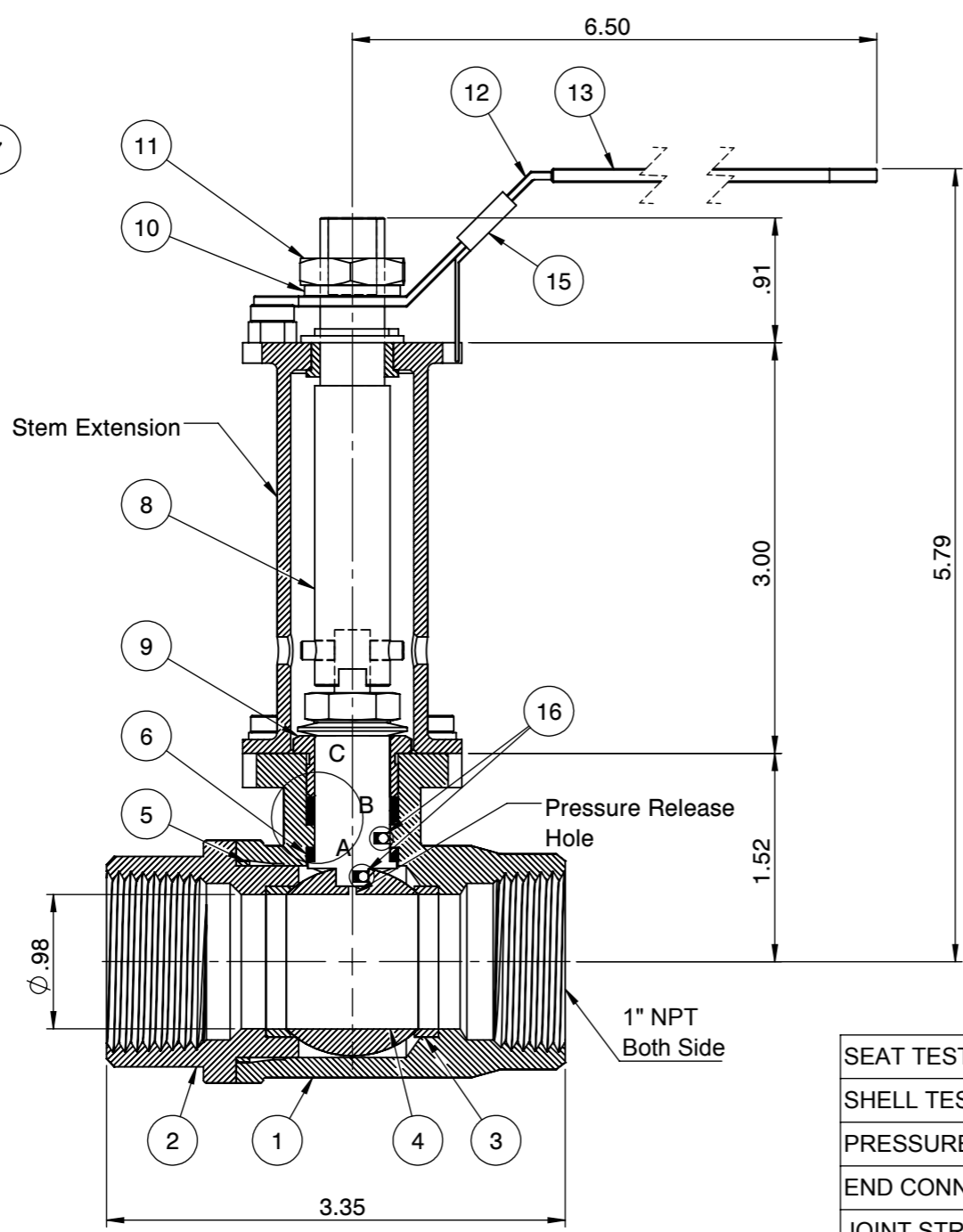
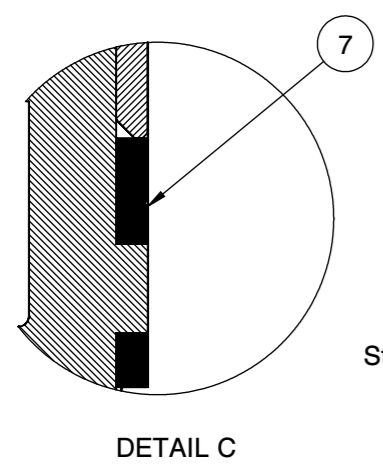

PRESSURE RATING 2000 WOG

SEAT TEST @ 80~100 PSI	ASME B16.34
SHELL TEST @ 2175 PSI	ASME B16.34
PRESSURE TEMPERATURE RATING	ASME B16.34
END CONNECTION	ASME B16.11
JOINT STRENGTH	ASME B16.34
WALL THICKNESS	ASME B16.34
BASIC DESIGN	ASME B16.34

No.	Parts	Material
1	Body	ASTM A351 CF8M
2	End Cap	ASTM A351 CF8M
3	Seat	Super-Tek (TFM 1600)
4	Ball	ASTM A351 CF8M
5	Gasket	Graphite
6	Thrust Washer	TFM
7	Stem Packing	TFM
8	Stem	A276-316 / 17-4PH
9	Gland	SS304
10	Handle Washer	SS304
11	Handle Nut	SS304
12	Handle	SS304
13	Handle Cover	PVC
14	Stop Screw	SS304
15	Locking Device	SS304
16	Anti-Static Device	SS316

FOR CERTIFIED
DRAWING CONSULT
FACTORY

Drawn by : M Date : June 17, 2019 Scale : Not To Scale Rev : 0
 Checked by : M Date : June 17, 2019 Unit : Inch Sheet : xxx
 Approved by : M Date : June 17, 2019 Material : See Notes

Drawing Title: NPT 1" FULL PORT BALL VALVE
 Drawing No.: DT-T23SSFFGL025XS3

FLO TITE™ 4815 W. 5th Street Tel : 910-738-8904
 Lumberton, NC 28358 Fax : 910-738-9112
 Website: www.flotite.com E-mail : flotite@flotite.com

REVIEW ALL STANDARD SOFT PARTS FOR APPLICATION COMPATIBILITY