

Fusion Series **2000 WOG** **SS** **Super-Tek Seat**
NON FIRESAFE PER API 607-5 **SIZE 3/8"**

T23-SS-F-F-G-O-010



QR CODE

Actuator ISO Mounting Flange (F04)

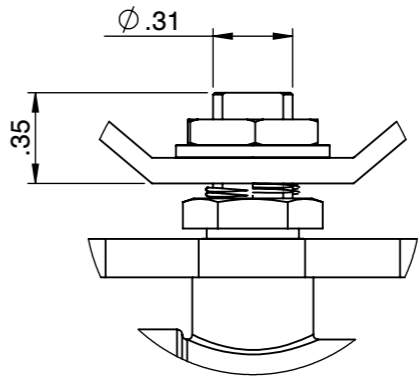
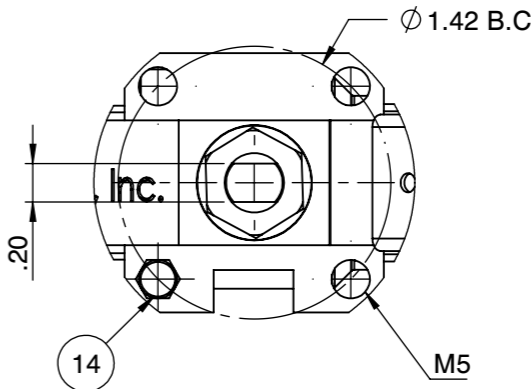

SS: Flo-Tite
T23SS
CF8M

3/8"
2000
WOG

1/4" - 1" Body marking

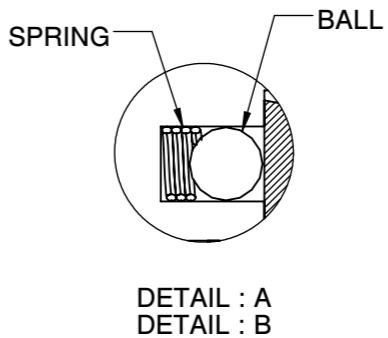

No.	Parts	Material
1	Body	ASTM A351 CF8M
2	End Cap	ASTM A351 CF8M
3	Seat	Super-Tek (TFM 1600)
4	Ball	ASTM A351 CF8M
5	Gasket	Graphite
6	Thrust Washer	TFM
7	Stem Packing	TFM
8	Stem	A276-316 / 17-4PH
9	Gland	SS304
10	Handle Washer	SS304
11	Handle Nut	SS304
12	Handle	SS304
13	Handle Cover	PVC
14	Stop Screw	SS304
15	Locking Device	SS304
16	Anti-Static Device	SS316

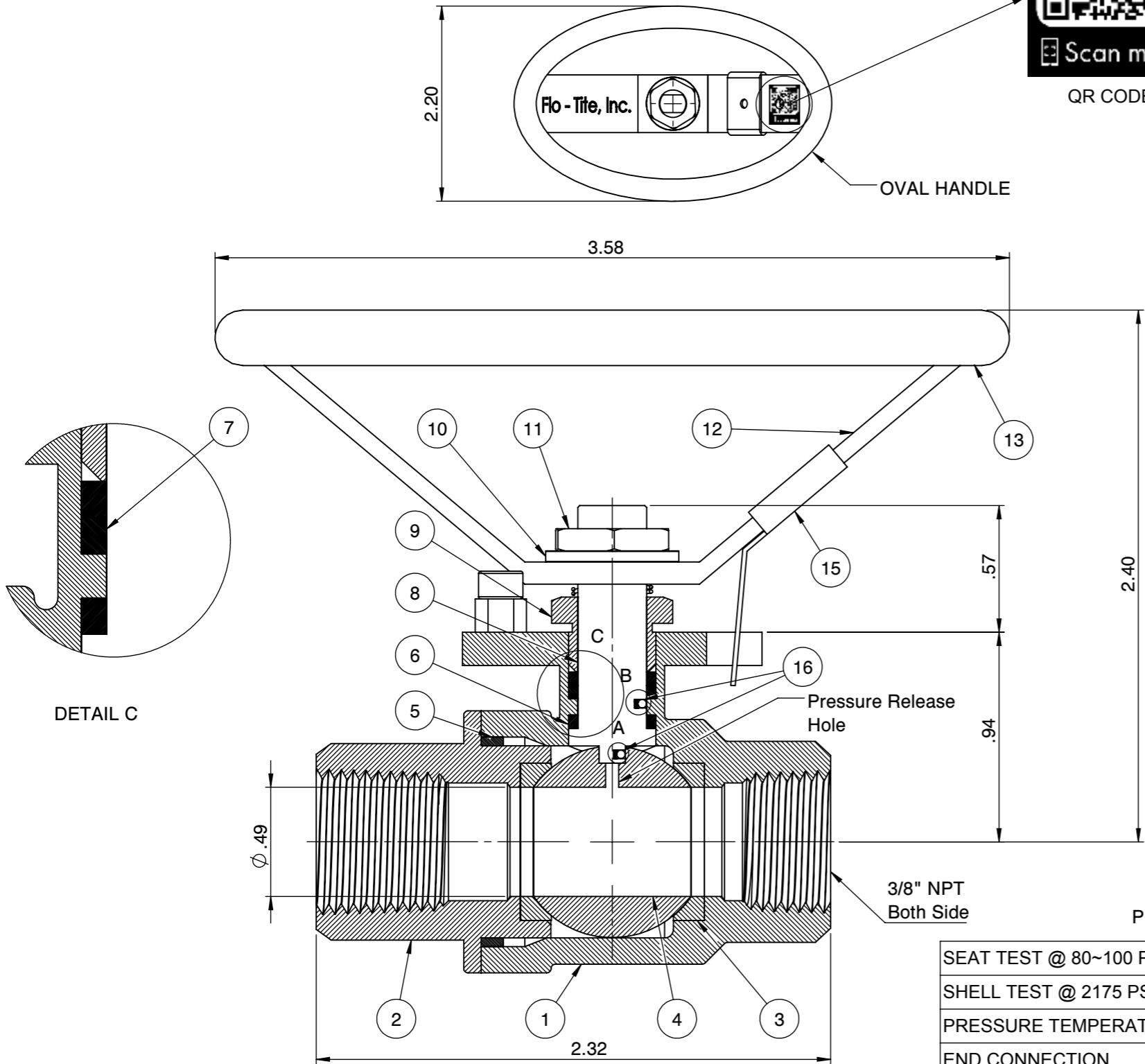

SEAT TEST @ 80~100 PSI	ASME B16.34
SHELL TEST @ 2175 PSI	ASME B16.34
PRESSURE TEMPERATURE RATING	ASME B16.34
END CONNECTION	ASME B16.11
JOINT STRENGTH	ASME B16.34
WALL THICKNESS	ASME B16.34
BASIC DESIGN	ASME B16.34

PRESSURE RATING 2000 WOG

FOR CERTIFIED
DRAWING CONSULT
FACTORY

Drawn by : M Date : June 21, 2019 Scale : Not To Scale Rev : 0
 Checked by : M Date : June 21, 2019 Unit : Inch Sheet : xxx
 Approved by : M Date : June 21, 2019 Material : See Notes

Drawing Title: NPT 3/8" FULL PORT BALL VALVE
 Drawing No.: DT-T23SSFFGO010



4815 W. 5th Street Tel : 910-738-8904
 Lumberton, NC 28358 Fax : 910-738-9112
 Website: www.flotite.com E-mail : flotite@flotite.com

REVIEW ALL STANDARD SOFT PARTS FOR APPLICATION COMPATIBILITY