

**Fusion Series**   **2000 WOG**   **SS**   **Super-Tek Seat**

**FIRESAFE PER API 607-5**   **SIZE 2"**

**T23-SS-F-G-G-L-050**



QR CODE

Actuator ISO Mounting Flange (F07)

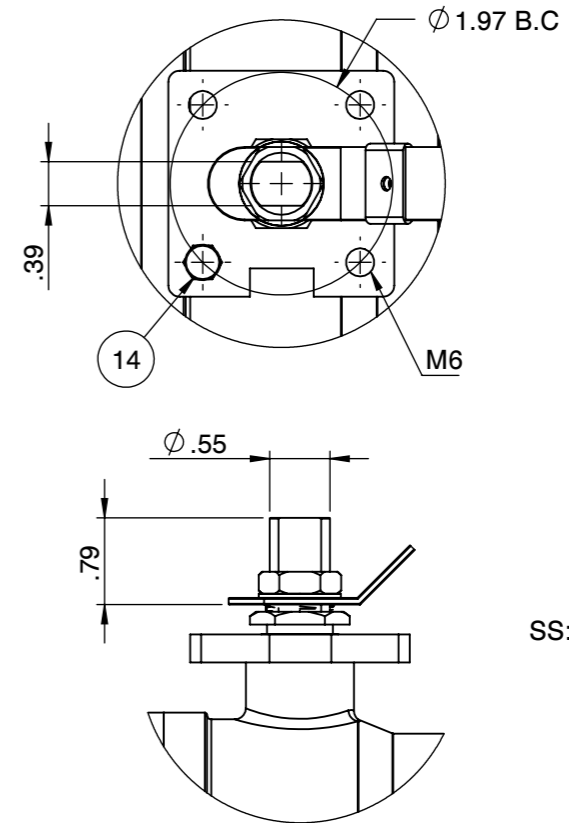

SS: Flo-Tite T23SS   CF8M 2000 WOG

2"   1-1/4" - 2" Body marking

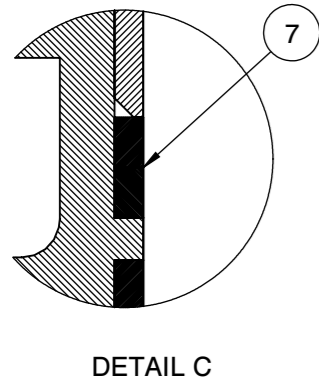

DETAIL C

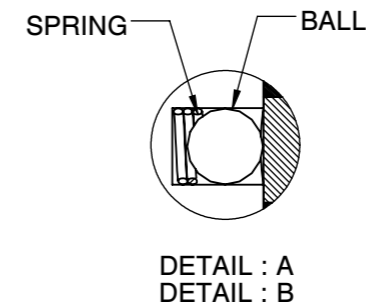
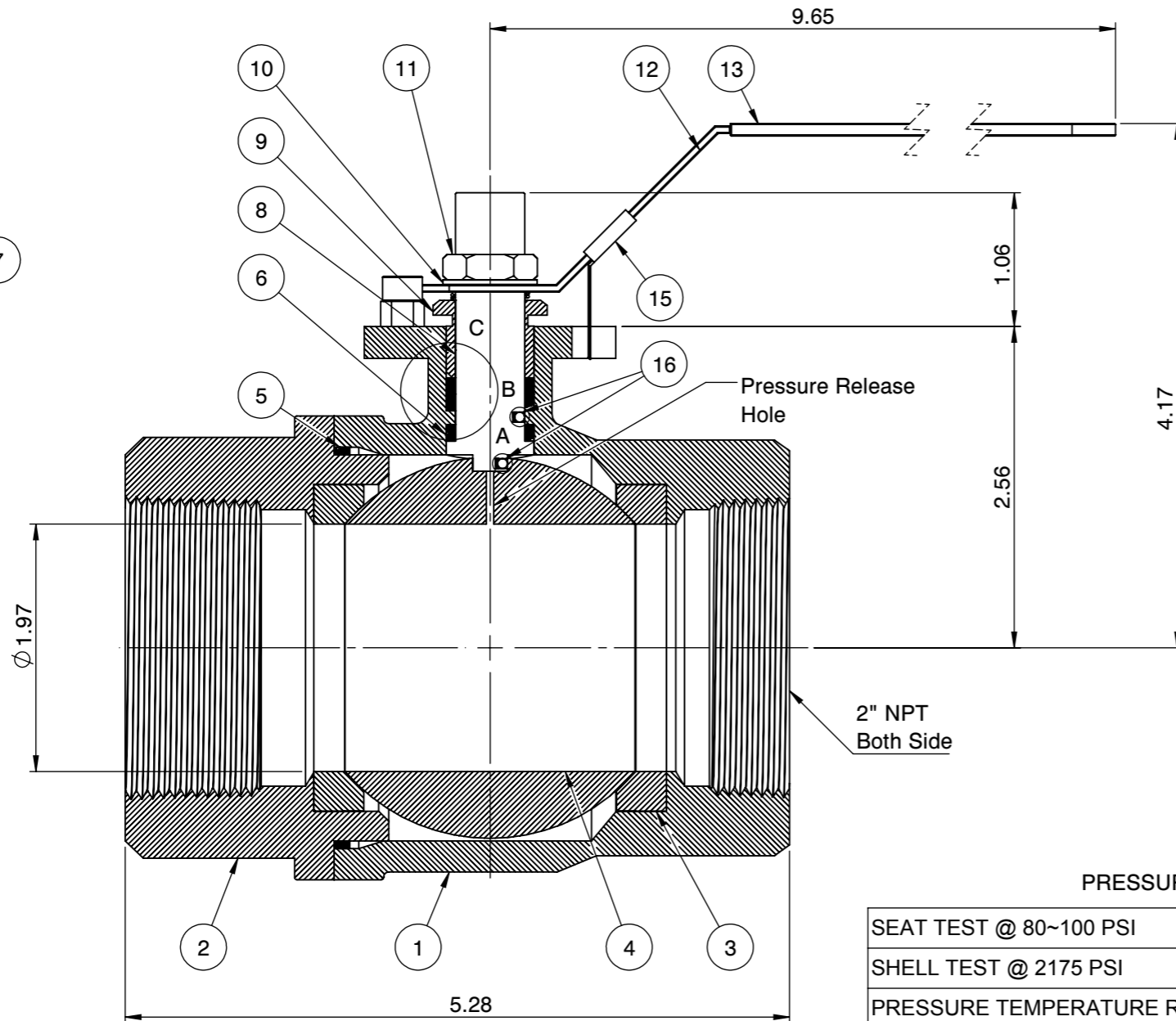

DETAIL : A  
DETAIL : B

PRESSURE RATING 2000 WOG

SEAT TEST @ 80~100 PSI	ASME B16.34
SHELL TEST @ 2175 PSI	ASME B16.34
PRESSURE TEMPERATURE RATING	ASME B16.34
END CONNECTION	ASME B16.11
JOINT STRENGTH	ASME B16.34
WALL THICKNESS	ASME B16.34
BASIC DESIGN	ASME B16.34

No.	Parts	Material
1	Body	ASTM A351 CF8M
2	End Cap	ASTM A351 CF8M
3	Seat	Super-Tek (TFM 1600)
4	Ball	ASTM A351 CF8M
5	Gasket	Graphite
6	Thrust Washer	TFM
7	Stem Packing	GRAPHITE
8	Stem	A276-316 / 17-4PH
9	Gland	SS304
10	Handle Washer	SS304
11	Handle Nut	SS304
12	Handle	SS304
13	Handle Cover	PVC
14	Stop Screw	SS304
15	Locking Device	SS304
16	Anti-Static Device	SS316

FOR CERTIFIED DRAWING CONSULT FACTORY

Drawn by : M   Date : June 24, 2019   Scale : Not To Scale   Rev : 0  
 Checked by : M   Date : June 24, 2019   Unit : Inch   Sheet : xxx  
 Approved by : M   Date : June 24, 2019   Material : See Notes

Drawing Title: NPT 2" FULL PORT BALL VALVE  
 Drawing No.: DT-T23SSFGGL050

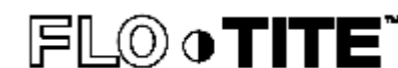

4815 W. 5th Street   Tel : 910-738-8904  
 Lumberton, NC 28358   Fax : 910-738-9112  
 Website: www.flotite.com   E-mail : flotite@flotite.com

REVIEW ALL STANDARD SOFT PARTS FOR APPLICATION COMPATIBILITY