

Trans-Flo Series
ANSI 300 316SS
TFM Seat
FULL PORT
Size 6" - 12"

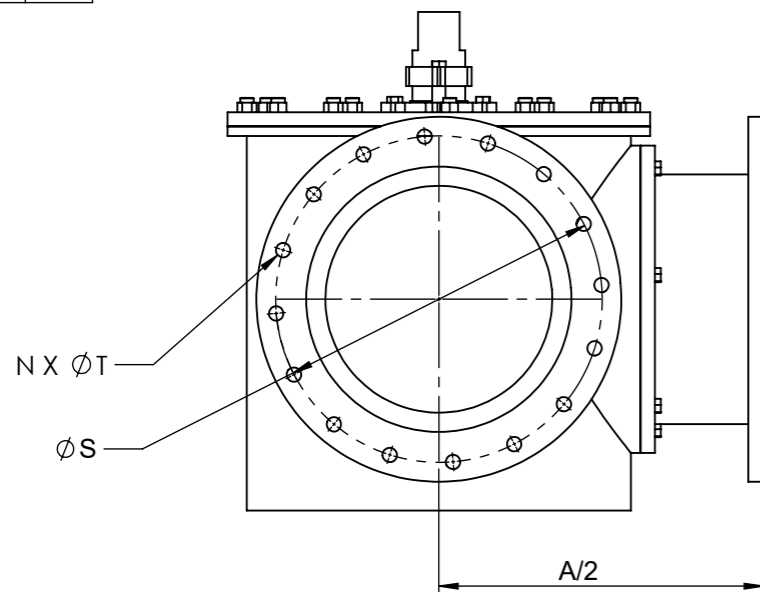

SIZE	Unit	A	B	C1	E	E4	F4	N	S	T	D	G	H	K	L	M	P	W	ISO
6"	Inch	18.42	5.91	7.14	10.37	5.91	12.5	12	10.62	0.87	4.92	3.5	3.5	1.89	2.99	1.378	1.77	1/2-13unc	F12
	mm	467.868	150.114	181.356	263.398	150.114	317.5	12	269.748	22.098	124.968	88.9	88.9	48.006	75.946	35.0012	44.958	1/2-13unc	F12
8"	Inch	23.93	7.87	8.37	11.91	7.87	15	12	13	1	6.5	4.59	4.59	2.36	3.37	1.772	2.36	5/8-11unc	F16
	mm	607.822	199.898	212.598	302.514	199.898	381	12	330.2	25.4	165.1	116.586	116.586	59.944	85.598	45.0088	59.944	5/8-11unc	F16
10"	Inch	30.27	9.84	9.27	13.6	9.84	17.5	16	15.25	1.14	6.5	4.59	4.59	2.76	4.33	1.772	2.36	5/8-11unc	F16
	mm	768.858	249.936	235.458	345.44	249.936	444.5	16	387.35	28.956	165.1	116.586	116.586	70.104	109.982	45.0088	59.944	5/8-11unc	F16
12"	Inch	31.53	11.81	10.24	14.96	11.81	20.5	16	17.75	1.25	6.5	4.59	4.59	TBA	TBA	2.165	2.76	5/8-11unc	F16
	mm	800.862	299.974	260.096	379.984	299.974	520.7	16	450.85	31.75	165.1	116.586	116.586			54.991	70.104	5/8-11unc	F16

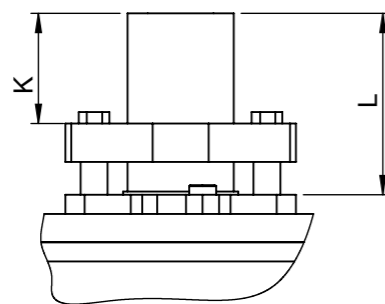
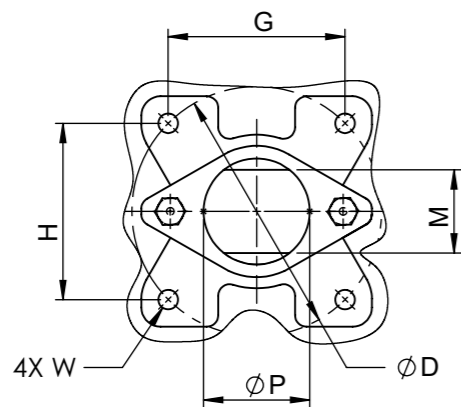
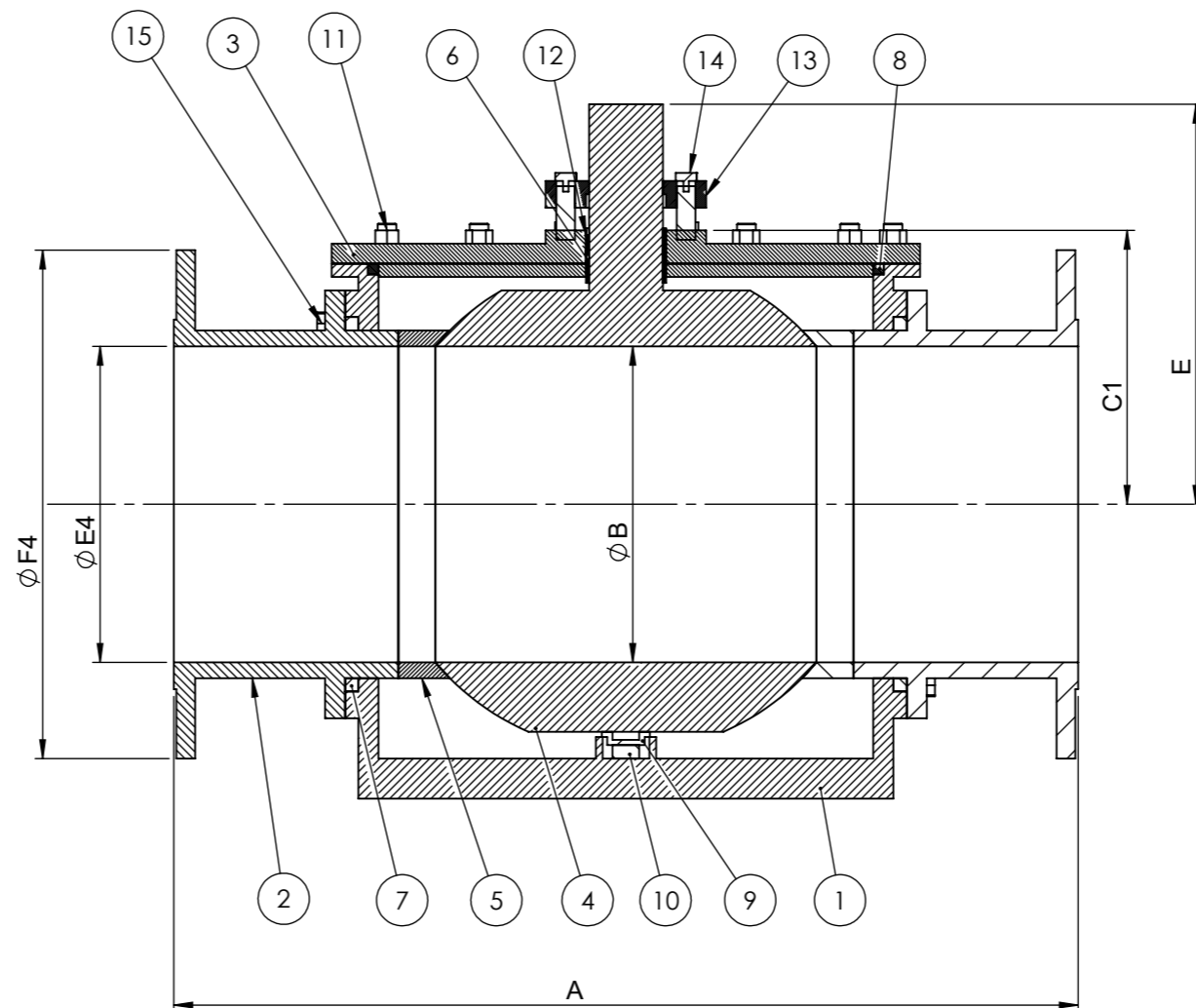

NOTE: FOR ALL THE FLOW PLANS, PLEASE CONSULT CATALOG 90 - 22 PAGE #15

NO	Name	Material	Qty
1	Body	ASTM A351 CF8M	1
2	End Caps	ASTM A351 CF8M	3
3	Bonnet	ASTM A351 CF8M	1
4	Ball & Stem	ASTM A351 CF8M	1
5	Seats	TFM	3
6	Stem Packing	TFM/Graphite *	1
7	Body Gaskets	50/50/Graphite *	3
8	Bonnet Gasket	50/50/Graphite *	1
9	Thrust Bearing	50/50/PEEK *	1
10	Anti-Static Springs	SS304	1
11	Bonnet Bolts	ASTM A193 B8	set
12	Packing Follower	SS304	1
13	Packing Gland	ASTM A351 CF8	1
14	Gland Bolts	SS304	2
15	Body Bolts	ASTM A193 B8	set

ANSI / FCI LEAKGE CLASS	SHUT-OFF CLASS V/VI
SHELL TEST @ 1125 PSI	ASME B16.34
PRESSURE TEMPERATURE RATING	ASME B16.34
END CONNECTION	ASME B16.11
JOINT STRENGTH	ASME B16.34
WALL THICKNESS	ASME B16.34
BASIC DESIGN	ASME B16.34

Drawn by : M Date : November 9, 2018 Scale : Not To Scale Rev : 0
 Checked by : M Date : November 9, 2018 Unit : Inch Sheet : xxx
 Approved by : M Date : November 9, 2018 Material : See Notes

Drawing Title: FLANGED FULL BORE BALL VALVE
 Drawing No.: DS-MPF30-SS-T-FFG-L-XXX



4815 W. 5th Street Tel : 910-738-8904
 Lumberton, NC 28358 Fax : 910-738-9112
 Website: www.flotite.com E-mail : flotite@flotite.com