

Tri-Pro Series	2250WOG	WCB	Metal Seat	FULL PORT	BUTT WELD	HPF43-CS-1-MGG-L-008-B1/B3-C5/C6
FIRE SAFE API 607-7			SIZE 1/4"			

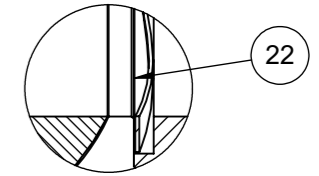

QR CODE

Actuator ISO Mounting Flange (F04)

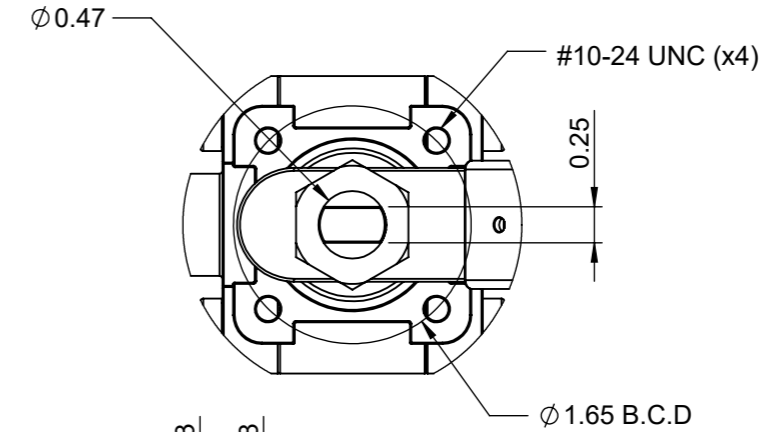

DETAIL C
SCALE 10 : 4

P-TYPE UNI-DIRECTION

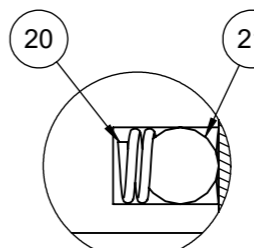
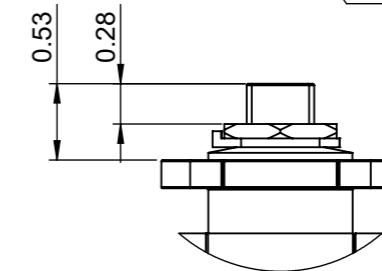
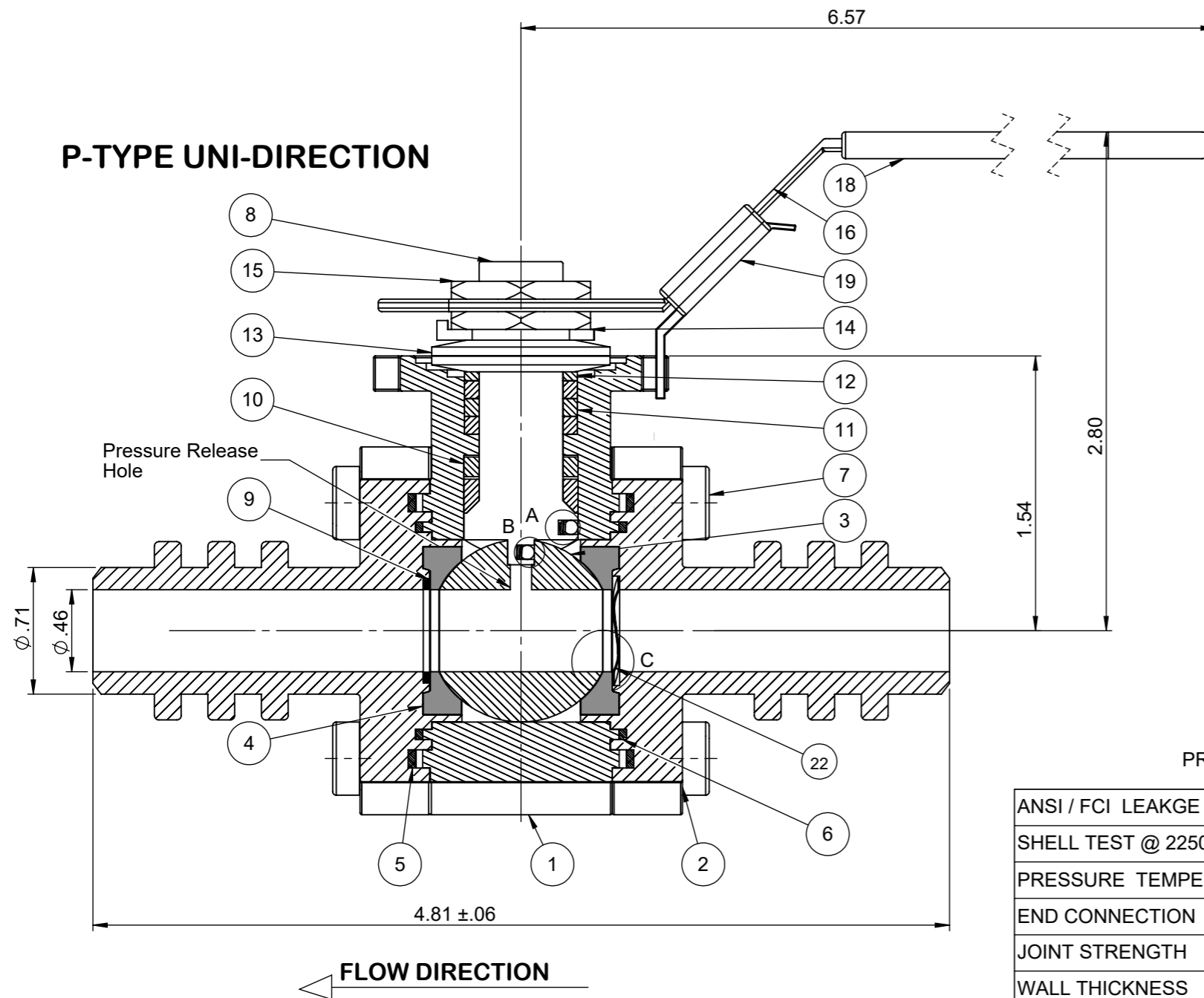

DETAIL : A
DETAIL : B

PRESSURE RATING 2250 WOG

ANSI / FCI LEAKGE CLASS	SHUT-OFF CLASS V/VI	NO	Name	Material
SHELL TEST @ 2250 PSI	ASME B16.34	1	Body	ASTM A216 WCB
PRESSURE TEMPERATURE RATING	ASME B16.34	2	Cap	ASTM A216 WCB
END CONNECTION	ASME B16.11	3	Ball	Forged SS316 Carbide Coated
JOINT STRENGTH	ASME B16.34	4	Seat	Forged SS316 Carbide Coated
WALL THICKNESS	ASME B16.34	5	Gasket (Inner)	Graphite
BASIC DESIGN	ASME B16.34	6	Gasket (Outer)	Graphite
		7	Bolt	EN3506 A2-70/ A193 B8
		8	Stem	17-4PH
		9	Seat Gasket	Graphoil
		10	Thrust Washer	NIT60
		11	Stem Packing	Graphite
		12	Packing Follower	SS304
		13	Belleville Washer	SS301
		14	Tap Lock Washer	SS304
		15	Stem Nut	SS304
		16	Handle	SS304
		17	Stopper	SS304
		18	Plastic Cover	Plastic
		19	Locking Device	SS304
		20	Anti-Static Spring	SS301
		21	Anti-Static Ball	SS316
		22	Wavo Spring	17-7/Inconel/A286

Drawn by :	M	Date :	November 9, 2018	Scale :	Not To Scale	Rev :	0
Checked by :	M	Date :	November 9, 2018	Unit :	Inch	Sheet :	xxx
Approved by :	M	Date :	November 9, 2018	Material :	See Notes		

Drawing Title:	BW 1/4"FULL BORE BALL VALVE
Drawing No.:	DT-HPF43-CS-1-MGG-L-008-B1/B3-C5/C6

FLO-TITE™ 4815 W. 5th Street Tel : 910-738-8904
 Lumberton, NC 28358 Fax : 910-738-9112
 Website: www.flotite.com E-mail : flotite@flotite.com

REVIEW ALL STANDARD SOFT PARTS FOR APPLICATION COMPATIBILITY