

**Tri-Pro Series**   **2250 WOG**   **316SS**   **TFM Seat**  
**FIRE SAFE API 607-7**   **SIZE 1-1/2"**

**HPS53-SS-3-F-G-G-L-40**

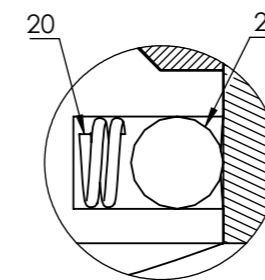

Actuator ISO Mounting Flange (F05)

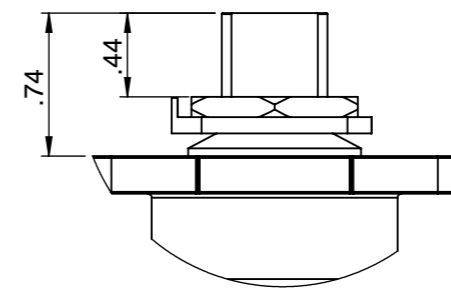
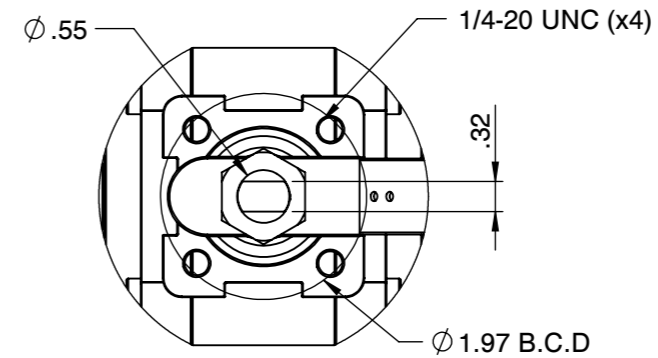

DETAIL : A  
 DETAIL : B

NO	Name	Material
1	Body	ASTM A351 CF8M
2	Cap	ASTM A351 CF8M
3	Ball	ASTM A351 CF8M
4	Seat	TFM
5	Gasket (Inner)	TFM
6	Gasket (Outer)	Graphite
7	Bolt	EN3506 A2-70/ A193 B8
8	Stem	17-4PH
9	Thrust Bearing	Carbon PTFE
10	Thrust Washer	50%SS PTFE
11	Stem Packing	Graphite
12	Packing Follower	SS304
13	Belleville Washer	SS301
14	Tap Lock Washer	SS304
15	Stem Nut	SS304
16	Handle	SS304
17	Stopper	SS304
18	Plastic Cover	Plastic
19	Locking Device	SS304
20	Anti-Static Spring	SS301
21	Anti-Static Ball	SS316

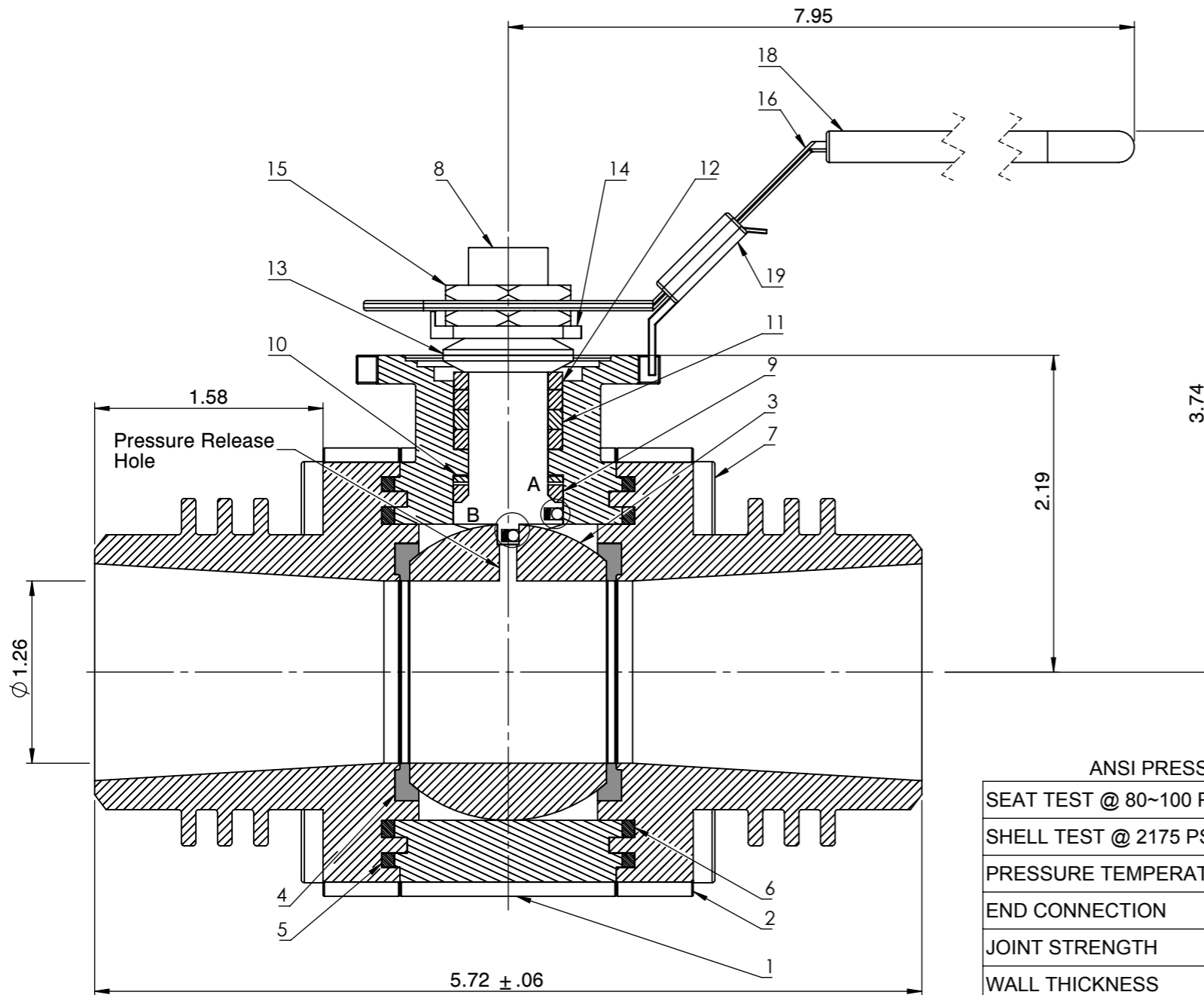

ANSI PRESSURE RATING CLASS 600/2250 WOG

SEAT TEST @ 80~100 PSI	ASME B16.34
SHELL TEST @ 2175 PSI	ASME B16.34
PRESSURE TEMPERATURE RATING	ASME B16.34
END CONNECTION	ASME B16.25
JOINT STRENGTH	ASME B16.34
WALL THICKNESS	ASME B16.34
BASIC DESIGN	ASME B16.34

FOR CERTIFIED DRAWINGS CONSULT FACTORY	Drawn by :	M	Date :	November 9, 2018	Scale :	Not To Scale	Rev :	0
	Checked by :	M	Date :	November 9, 2018	Unit :	Inch	Sheet :	xxx
	Approved by :	M	Date :	November 9, 2018	Material :	See Notes		

Drawing Title:	BW 1-1/2" REDUCED BORE BALL VALVE
Drawing No.:	DT-HPS53SS3FGGL-40

**FLO TITE™**

4815 W. 5th Street    Tel : 910-738-8904  
 Lumberton, NC 28358    Fax : 910-738-9112  
 Website: www.flotite.com    E-mail : flotite@flotite.com

REVIEW ALL STANDARD SOFT PARTS FOR APPLICATION COMPATIBILITY