



Multi-Choice Sanitary Ball Valves

3PC True Bore Extended Tube & Clamp Ends

High Purity Series

Clamp End

Model 350



Size Range:

1/2" ~ 4"

Temperature Range:

-20° ~ 400°F

Maximum Pressures:

1000 MAWP/WOG

Extended Tube End

Model 370



Multi-Choice Sanitary

STANDARD PRODUCT NUMBERS

350-SL-5-TTT-L	(PTFE Seats)
350-SL-5-FFF-L	(TFM Seats)
370-SL-7-TTT-L	(PTFE Seats)
370-SL-7-FFF-L	(TFM Seats)

DESIGN FEATURES

- Flo-Tite's Sanitary Ball Valves offer a high finish in both its standard surface of Ra 25-30. Optional finer Ra and Electropolish finish available thru 8-12 Ra.
- True Bore Port Design eliminates pooling traces of media and improves flow characteristics for greater efficiency.
- Full body cavity fillers available to reduce the possibility of contamination by entrapment of process fluids in the void normally found between the ball and valve body in conventionally designed ball valves. Cavity fillers are a major plus in applications where cross contamination is a concern.
- C.I.P. valves - clean-in-place
- All valve ends incorporate a special boss for welding purge port connections.
- Extended tube ends are suitable for in-line Automatic Orbital Welding without disassembly.
- Safety lock handle Prevents accidental movement of valve handles.

Same Proven Design as Our Industrial Valves,
but designed specifically for the Sanitary Market.

www.flotite.com

Bill of Materials

No.	Part Name	Material	Qty
1	Body	ASTM A351 CF3M	1
2	Caps	ASTM A 351 CF3M	2
3	Stem	SS316L	1
4	Packing Follower	SS304	1
5	Disc Spring Washers	SS301	2
6	Lock Washer	SS304	1
7	Ball	ASTM A351 CF3M	1
8	Seat Cavity Fillers #	PTFE/TFM	2
9	Packing #	PTFE/TFM	2
10	Thrust Washer #	PTFE/TFM	1
11	Set Sleeve	SS304	3
12	Set Bolt	SS304	1
13	Thin Nut	SS304	2
14	Bolt	SS304	1
15	Handle	SS304	1
16	Locating Lock	SS304	1
17	Plastic Cover	Plastic	1

Parts included in the repair kits

Specifications

Valve bodies and end connections are high quality investment cast and solution annealed. Body shell wall thickness complies with ASME B16.34.

BPEa compliant with < 3% ferrite and 0.005 to 0.007 sulfur content in the extended tube ends for orbital welding. (Consult factory)

Valve stems are blow-out proof for maximum safety and comply with ASME B16.34.

All standard materials of construction comply with FDA requirements and all soft goods meet USP Class IV standards.

Body & Trim Materials

The valve body and ends are castings made from 316L grade stainless steel conforming to ASTM A351 CF3M which improves the resistance to intergranular corrosion caused by welding. Welded end castings have low sulfur content of 0.005-0.017%. The ball & stem are from stainless steel conforming to SS316L. A lower cost version 316/CF8M center body with SS316L end connections is also available.

Valve Seat Options

(T) PTFE is the material of choice where the characteristics of low friction, high durability, excellent thermal resistance, or chemical inertness are required. **Recommended for water, food, or corrosive chemicals.**

(F) TFM offers all of the properties of reinforced PTFE with greater strength, toughness, and improved thermo-mechanical properties. This offers lower coefficient of friction for lower torques and less permeability, reduced cold flow deformation, and enhanced deformation recovery.

(C) Cavity Filler Seats are available for all valves. **It eliminates most crevices, gaps, or pockets between the ball & valve body**, reducing the risk of contaminants being trapped or solidification of products.

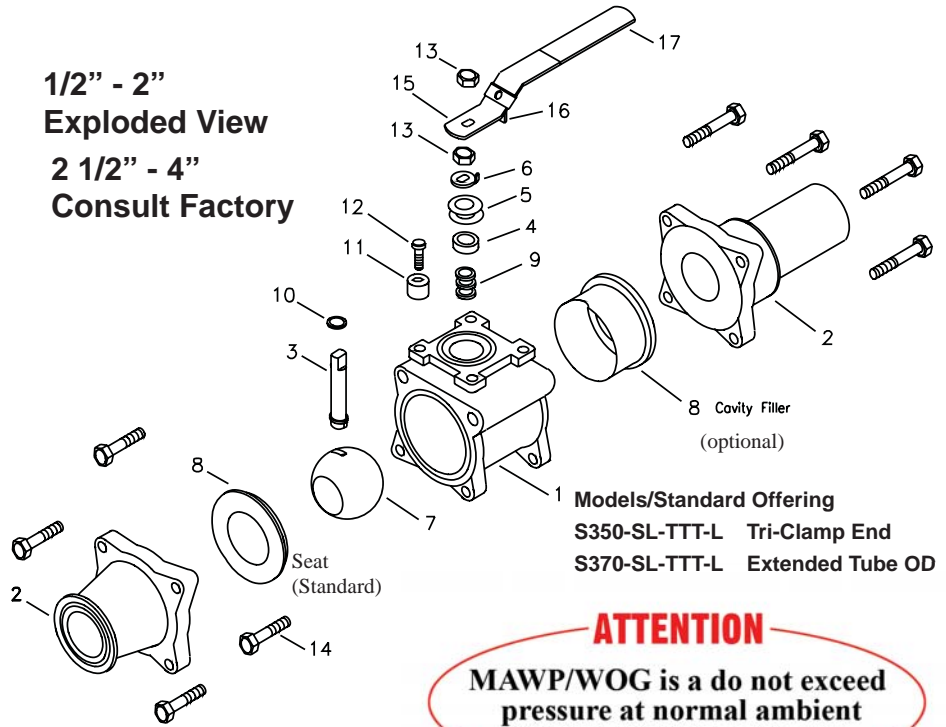

Pressure Ratings

Valve Body: 1000psi MAWP/WOG

Steam Rating: 150psi WSP

Vacuum Rating: 20 micron

ATTENTION
MAWP/WOG is a do not exceed pressure at normal ambient NPT & Weld End Models

Pressure/Temperature Chart

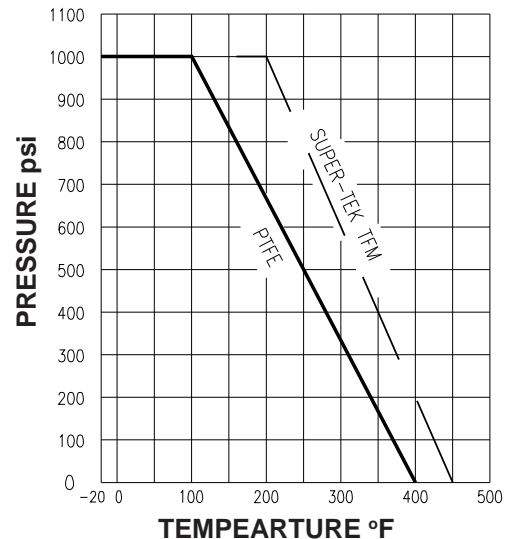

Design and Technical Data

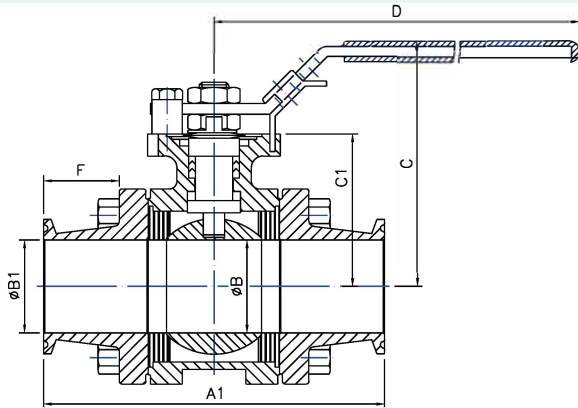

TRI-CLAMP END MODEL S350

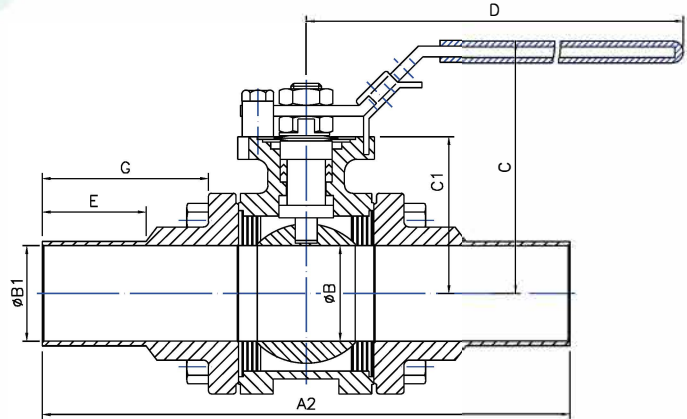

EXTENDED TUBE O.D. B/W END MODEL S370

Dimensions

SIZE in mm	A1	A2	B	B1	C	C1	D	E	F	G	Cv	Torque	In-Lbs/Nm	Weight	
												w/o CF	w/ CF	S350	S370
1/2" 15	3.60 91.5	6.00 152.4	0.370 9.4	0.370 9.4	2.60 66	1.54 39	6.50 165	1.50 38.1	0.94 24	2.14 54.4	9.5	65 7.3	72 8.1	2 0.9	3 1.4
3/4" 20	4.11 104.5	6.00 152.4	0.620 15.8	0.620 15.8	2.60 66	1.54 39	6.50 165	1.50 38.1	1.20 30.5	2.14 54.4	30	80 9.0	100 11.3	3 1.4	4 1.8
1" 25	4.48 113.8	6.50 165.1	0.870 22.1	0.870 22.1	2.91 73.9	1.66 42	6.50 165	1.50 38.1	1.23 31.3	2.24 56.9	65	120 13.6	174 19.7	4 1.8	5 2.3
1 1/2" 40	5.06 128.4	7.50 190.5	1.370 34.3	1.370 34.3	3.62 91.9	2.25 57.3	7.87 200	1.50 38.1	1.12 28.5	2.34 59.5	205	238 26.9	295 33.3	7 3.2	10 4.5
2" 50	5.75 146	8.50 215.9	1.870 47.5	1.870 47.5	4.53 115.1	2.95 75	7.87 200	1.77 45	0.99 25.2	2.37 60.1	420	380 42.9	550 62.1	10 4.5	16 7.3
2 1/2" 65	6.85 174	10.0 254	2.370 60.2	2.370 60.2	5.04 128	3.39 86	9.65 245	2.19 55.6	1.15 29.3	2.73 69.3	675	610 68.9	1000 113	20 9.1	23 10.4
3" 80	7.40 188	11.5 292.1	2.870 72.9	2.870 72.9	6.42 163.1	3.72 94.5	15.4 390	1.77 45.1	1.08 27.5	3.13 79.6	989	840 94.9	1220 137.8	32 14.5	33 15.0
4" 100	8.76 222.5	12.5 317.5	3.834 97.4	3.834 97.4	7.09 180.1	4.35 110.5	15.4 390	2.00 50.8	1.25 31.7	3.12 79.3	1765	1850 209	2600 293.8	55 24.9	61 27.7

Valve end connections are interchangeable within the multi choice sanitary valve series

Mounting Dimensions

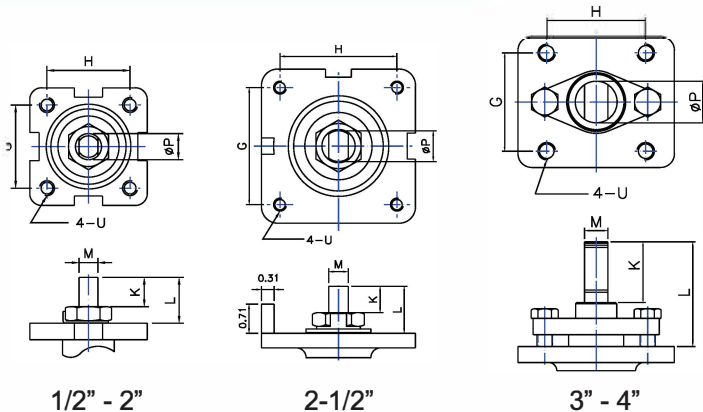

SIZE in mm	G	H	K	L	M	P	U	ISO PAD
1/2" 15	1.17 29.7	1.17 29.7	0.31 8	0.55 14	0.250 6.35	0.375 9.5	#10-24UNC	F04
3/4" 20	1.17 29.7	1.17 29.7	0.31 8	0.55 14	0.250 6.35	0.375 9.5	#10-24UNC	F04
1" 25	1.17 29.7	1.17 29.7	0.31 8	0.55 14	0.250 6.35	0.375 9.5	#10-24UNC	F04
1 1/2" 40	1.39 35.4	1.39 35.4	0.43 11	0.75 19	0.315 8	0.438 11.1	1/4-20UNC	F05
2" 50	1.95 49.5	1.95 49.5	0.55 14	0.91 23	0.374 9.5	0.625 15.9	5/16-18UNC	F07
2 1/2" 65	2.84 72.1	2.84 72.1	0.69 17.5	1.14 29	0.472 12	0.750 19.1	5/16-18UNC	F10
3" 80	2.84 72.1	2.84 72.1	1.75 44.5	3.07 78	0.669 17	1.10 28	1/2-13UNC	F10
4" 100	2.84 72.1	2.84 72.1	1.75 44.5	3.07 78	0.669 17	1.10 28	1/2-13UNC	F10

Flo-Tite's High Purity Series is the Flo-Tite line of clean ball valves for the Food, Pharmaceutical and Bioprocessing Industries. The valves are designed for applications which require high flow capacity at minimum pressure drop, where sterility, cleanability, and drainability are essential for product quality and perfection. The sanitary valve port matches tube ID dimensions, provides tight shutoff, and has exceptional performance in many service applications.

Flo-Tite 3 PIECE VALVES are designed for easy removal from the pipeline so that all valve components can be easily and quickly cleaned. All valve hardware is Stainless Steel Type 304 as standard.

Fugitive Emission

In applications where it is essential to eliminate escape of volatile organic compounds (VOC) into the atmosphere, a Fugitive Emission kit can be mounted directly onto the ISO platform of the valves. The kits are available for all sizes and can be operated manually or with an actuator. Each housing has a threaded port for connecting tubing or instrumentation for registering potential leaks.



Purge Ports

Valve bodies and ends may be supplied with additional purge ports to allow draining of the body cavity or for flushing the lines. This enables in-line maintenance for clean in place (CIP) or steam in place (SIP) where traces of product and contaminants must be effectively removed from all pockets.

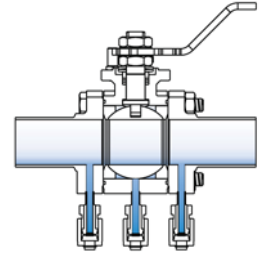

Assembly and Packaging

Flo-Tite operates a fully equipped clean room for the assembly of valves. All valves are cleaned, dried, assembled, 100% leak tested, inspected and finally, if required, packaged in a hermetically sealed bag filled with dry nitrogen. Each valve is individually tagged for traceability and material certification will be provided on request.

Surface Finishes

All surfaces which come directly or indirectly in contact with the product are machined to 0.625 micron (25 micro inch Ra, Grit 180). Mechanically polished to higher levels of surface finish up to 0.25 micron (10 micro inch Ra, Grit 320) are available including internal or external Electropolishing.

SURFACE DESIGNATION			MECHANICALLY POLISHED			
FLOTITE CODE	ASME BPE	GRIT	Ra Average		Ra Max	
			μ-in	μ-m	μ-in	μ-m
A	SFV 1	GRIT 320	15	0.375	20	0.50
B	SFV 2	GRIT 240	20	0.50	25	0.625
C	SFV 3	GRIT 180	25	0.625	30	0.75

Automations of All Types



SURFACE DESIGNATION			MECHANICALLY AND ELECTROPOLISHED			
FLOTITE CODE	ASME BPE	GRIT	Ra Average		Ra Max	
			μ-in	μ-m	μ-in	μ-m
D	SFV 4	GRIT 320	10	0.25	15	0.375
E	SFV 5	GRIT 240	15	0.375	20	0.50
F	SFV 6	GRIT 180	20	0.50	25	0.625

- Electropolished valves are solution cleaned and bagged as standard
- All materials of construction comply with FDA Requirements
- Material test reports available
- Pressure rating - 1000 MAWP/WOG
- **clamps & gaskets can lower body pressure rating - C/F**
- For additional technical information see Tech Bulletin page 45.

Steam Ratings:

150 PSI WSP
250 PSI available with Super-Tek II seats.

Vacuum Service to 25 torr

Standards

ANSI B16.34
ISO 5211
ASME BPEa
MSS - SP25



Flo-Tite, Inc.
4815 West 5th St.
Lumberton, NC 28358

P. O. Box 1293
Lumberton, NC 28359
Website: www.flotite.com

Tel: (910) 738-8904
Fax: (910) 738-9112
E-mail: flotite@flotite.com