



Flo-Tite Uni-Flo Series **Models SF150 and SF300** **Flanged End Ball Valves** **Installation, Operation and Maintenance Manual**

Note: Before using a valve, read the entire IOM carefully and make sure you have a clear understanding of all information included.

This manual describes the procedures for the safe and efficient installation, operation and maintenance of Flo-Tite Flanged Series Ball Valves. **Failure to follow the procedures in this manual may result in Flo-Tite warranties being voided.** Problems with the operation and maintenance of these valves should be directed to the nearest Flo-Tite Representative.

The Flo-Tite Flanged Series are designed as one piece body. This line of valves utilizes the “free floating” ball principle. The ball is not fixed, but is free to move with the line pressure. As a result, these valves are capable of tight shut-off with the flow in either direction or dead-ended, regardless of the position of the valve in the line. The downstream seat, which is opposite the pressurized side, of a closed valve must carry the load exerted by the line pressure on the ball, while the upstream seat is subject to little load or wear. For this reason, it is sometimes possible to increase useful seat life by turning the valve end-for-end in the pipeline.

NOTE: Please note that Models SF150 and SF300 are supplied in two size ranges, ½” to 2” and then 3”-12” . Instructions and components may be different by size range. Please ensure that the correct size range instructions and drawing reference is used for the valve being serviced.

INSTALLATION:

A. Receiving and Preparation Procedure

- A1. Remove shipping protection
- A2. Inspect the valve(s) for transportation damage*
- A3. Inspect the valve bore and remove any debris
- A4. Cycle the valve and inspect the valve for smooth operation, size permitting
- A5. As shipped from the factory, valves may contain a silicone based lubricant. This is for break-in and may be removed if it is objectionable for a particular application by disassembling and solvent washing.

*If transportation damage is found, immediately take pictures for record purposes and contact the inbound carrier to submit a claim.

B. Installation Procedure

B1. General – The valve may be fitted in any position in the pipeline. Prior to installing the valve, the pipe on either side of the intended installation should be checked to be free of dirt, debris, weld slag, etc. to prevent damage to the seats, seals and surface of the ball. The piping must also be free of tension or compression.

WARNING – Never use the valve as a pipe support or structural member.

B2. Installation of the Flo-Tite Flanged Series valves is accomplished by inserting the valve between flanges attached to piping and supplied by others and attaching the valve to the mating flanges with fasteners of the size and type specified by industry standards. Fasteners should be tightened in a “star” pattern.

Caution – Ensure that mating flanges are of the same size, type and pressure rating as the valve and that fasteners are of the size and type approved for the flange.

B3. Valves with actuators should be checked for actuator-valve alignment. Angular or linear misalignment will result in high operational torque. Electric and/or pneumatic connections should be made in accordance with the correct actuator IOM instructions.

C. OPERATION:

C1. Manual operation of the valve is accomplished by turning the handle ¼ turn (90 degrees).

*The valve is open when the handle is “in-line” with the valve or pipeline. The valve is closed when the handle is “across” or perpendicular to the valve or pipeline.

C2. Flo-Tite Flanged Series valves can be operated with either electric or pneumatic actuators. For instructions on installation and operation, refer to the IOM for the correct actuator.

C3. Flo-Tite Flanged Series valves may include one of several different styles of limit switches and positioners. Please refer to the appropriate IOM for each device.

MAINTENANCE:

CAUTION – Ball valves can trap fluid in the ball cavity when closed. Be prepared to capture and manage any liquid retained in the valve body when disassembling the valve.

WARNING – **If the valve has been in hazardous fluid, review applicable MSDS sheet and decontaminate the valve before disassembly. All persons involved with the disassembly should wear personal protective equipment such as aprons, gloves, face shield, etc. to prevent personal injury.**

Access to the valve internals starts with relieving pressure in the pipeline. Turn the valve handle to the 45 degree, half open, position and flush the line, when applicable, to remove any hazardous material from the line. Consult the metal tag attached to the valve body to determine the correct seat and seal materials. Repair kits can be ordered from the local Flo-Tite Representative. This should be done prior to any disassembly work.

CAUTION - Valves with actuators, limit switches or positioners should have these devices disassembled from the valve prior to disassembling of the valve.

WARNING- **Use extreme caution disconnecting any electrical and/or pneumatic sources to the valve to protect against personal injury. Isolate the valve actuator prior to disconnecting.**

Stem Packing

Stem seal leakage may be corrected without disassembly. Tighten the packing gland nuts one flat at a time alternating between nuts, until leakage stops. If leakage continues, or the valve’s operating torque becomes excessive, the seals are worn and replacement of the packing will be necessary.

WARNING- **Do not remove packing gland while the line is under pressure. Personal injury could occur.**

D. Valve Disassembly-

WARNING – Use extreme caution when removing the flanged valve from the pipeline to prevent personal injury that may be caused by “cold springing” of the piping.

CAUTION – valves shall be adequately supported prior to unfastening the studs and nuts that hold the valve in line and secured with lifting straps or slings to hold the weight of the valve.

D1. Remove the flange bolts and nuts and lift the valve from the line for servicing. Note – care should be taken to avoid scratching or damaging the flange gaskets. Damaged gaskets must be replaced prior to reinstalling in the line.

D2. Safely place the valve on a clean, secure and stable work surface. Protect the flange faces when handling to prevent scratching and damage.

D3. Match mark the body and body end to insure correct alignment when the valve is reassembled.

D4. Remove body cap. One body seal and seat should come out with the body end.

D5. The ball may be removed by first placing the valve in the fully closed position. Use a lifting strap and lifting device for safety purposes when the weight of the ball dictates

CAUTION – Use extreme care in handling the ball to avoid damage.

D6. Remove the second seat and seal.

D7. Remove Stem -

a.) ½” to 2” valves – Remove handle nut, handle, lock washer, Belleville washer, packing follower, packing protector, stem packing, o-ring, packing protector and stem.

b.) 3” to 12” – Lose screw on handle and then remove handle, snap ring, travel stopper, gland bolt, stop housing, housing bolt, packing gland, lock washer, Belleville follower, packing protector, stem packing, o-ring, thrust washer and stem.

The stem must be removed from the inside of the body. Gently tap the top of the stem with a non-metallic mallet. The thrust washer should come out with the stem. Stem packing can now be removed. If a packing pick is used to remove packing, care must be taken not to scratch any surface.

Visual Inspection-

Clean and inspect all metal parts. It is not necessary to replace the ball and stem unless the seating surfaces have been damaged by abrasion or corrosion. Flo-Tite strongly recommends that all seats, seals and packing be replaced whenever a valve is disassembled for reconditioning. This is the surest protection against subsequent leakage after reassembly. Replacement parts are sold in kit form. Refer to the metal tag attached to the side of the valve body to identify the specific sealing materials used. Kits can be obtained via the local Flo-Tite Distributor. Replacement parts should be purchased prior to valve disassembly. Required information to purchase replacement parts include:

- a. Line size
- b. Model designation
- c. Seat/seal materials – see stamping on metal tag attached to the valve body.

Valve Reassembly -

Note- the valve may be reassembled and operated dry when no lubricants are allowed in the system; however, a light lubricant on the ball and stem will aid in assembly or reduce initial operating torque. Lubricant used must be compatible with the intended system fluid.

Install one new seat and seal in the body cavity with the spherical curvature facing the ball. Replace the stem in the reverse order from above based on valve size, including reattaching the handle. Turn the handle to the closed position. This will align the stem and the ball. Slide the ball into position. Turn the handle to the open position to help hold the ball in place. Install the second seal and seat into the body end.

Place the body seal gasket into the shoulder counter-bore at the flange in the valve body. Using the match marks to realign the body and body end, carefully place the cap end back into the body. Install the cap end nuts and tighten in a star pattern to the torque values specified below.

Note: Make sure ball is in closed position before tightening up the end connections.

WARNING- extreme care must be exercised during tightening of the body end nuts to make sure that complete engagement of studs with the body flange is maintained. There should be at least one stud thread exposed on each side.

Cycle the valve slowly, with a gentle back and forth motion to build gradually to a full quarter turn. By cycling slowly, the new seat lips will conform to the seal shape against the ball. An initial fast turning motion, at this point, may cut the seats before they have a chance to form the proper seal. When possible and practical, test the valve prior to reinstalling into the pipeline.

Reinstallation-

Carefully inspect the faces of both the valve flanges and the mating flanges to ensure they are clean and undamaged. Place the valve in the preferred position and support it from moving. Install a sealing gasket between each pair of flanges and reinsert the bolting and hand tighten. Secure the bolting to the recommended torque values in a star pattern to ensure that the gasket is compressed evenly around the entire circumference.

Repair Kits –

Repair kits typically consist of replaceable seats, body seals and packing seals. Refer to the unit nameplate, as shown below, to confirm what materials are currently installed. Contact your local Flo-Tite Representative to order and receive the kits prior to any maintenance work.

VALVE - SOFT PARTS							
SEAT	STEM SEALS		BODY SEAL		O-RINGS		
TFM	F	TFM	F	TFM	F	VITON	V
CTFM	Y	CTFM	Y	CTFM	Y	EPDM	E
PTFE	T	RPTFE	X	PTFE	T	PTFE	T
RPTFE	R	PTFE	T	RPTFE	R	BUNA	B
50/50	S	RPTFE	R	50/50	S	NONE	N
UHMWPE	U	50/50	S	UHMWPE	U		
PEEK	P	UHMWPE	U	PEEK	P		
Cavity Filled	C	PEEK	P	Graphite	G		
Metal	M	Graphite	G	Kel-F	K		
Kel-F	K						

Flo-Tite's marking system follows MSS SP-25-1998

Valve Markings- Casted into valve bodies include the following; Flo-Tite Name, Model Numbers, Body Material, Valve Size, & Class Pressure Rating

All Flo-Tite valves have metal nameplates spot welded to the valve body.

Standard Trim Soft Parts

ID-Codes

Seat material
Stem seal material

Flo-Tite Name

Flo-Tite Name
Valve Model



Valve Side A

Viton O-ring
Body seal material



Valve Side B

ANSI Class
Body Material

Bill of Materials / Standard Bore Valves

No.	Name	Stainless Steel	Carbon Steel
1	Body	ASTM A351 CF8M	ASTM A216 WCB
2	Cap	ASTM A351 CF8M	ASTM A216 WCB
3	Stem*	SS316	SS316 / SS304
4	Packing Follower	SS304	SS304
5	Belleville Washer	SS301	SS301
6	Lock Washer	SS304	SS304
7	Ball	SS316	SS316 / SS304
8	Seat	TFM	TFM
9	Gasket	RPTFE / Graphite	RPTFE / Graphite
10	Stem Packing	TFM / Graphite	TFM / Graphite
11	Packing Protector	50%PTFE+SS316	50%PTFE+SS316
12	Thrust Washer	25%Carbon+TFM	25%Carbon+TFM
13	Anti-Static	SS304	SS304
14	Valve Stop	SS304	SS304
15	Handle	SS304	SS304
16	Locking Device	SS304	SS304
17	Handle Sleeve	Plastic	Plastic
18	Thin Nut	SS304	SS304
19	Bolt	SS304	Carbon Steel
20	O-Ring	Viton	Viton

1/2"-2" SF150/SF300 Exploded View

Repair Kits
Soft Parts
Item # 8, 9,
10, 11, 12, 20

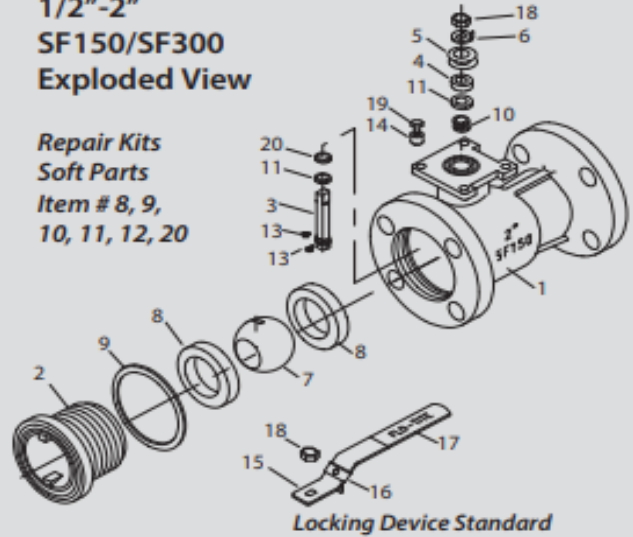

Locking Device Standard

New 2PC body design also available
Consult factory. Models RF15/RF30

Bill of Materials

No.	Name	Stainless Steel	Carbon Steel
1	Body	ASTM A351 CF8M	ASTM A216 WCB
2	Cap	ASTM A351 CF8M	ASTM A216 WCB
3	Stem*	SS316	SS316 / SS304
4	Packing Gland	ASTM A351 CF8	ASTM A351 CF8
5	Belleville Follower	SS304	SS304
6	Ball	SS316	SS316 / SS304
7	Seat	TFM	TFM
8	Stem Packing	TFM / Graphite	TFM / Graphite
9	Packing Protector	50%PTFE+SS316	50%PTFE+SS316
10	Gasket	RPTFE / Graphite	RPTFE / Graphite
11	Thrust Washer	25%Carbon+TFM	25%Carbon+TFM
12	O-Ring	Viton	Viton
13	Anti-Static	SS304	SS304
14	Travel Stopper	SS304	Steel
15	Snap Ring	Plated Steel	Plated Steel
16	Handle	Ductile Iron	Ductile Iron
17	Gland Bolt	SS304	Steel
18	Stop Housing	SS304	SS304
19	Housing Bolt	SS304	SS304
20	Set Screw	Steel	Steel

* Stem Optional Material 17-4PH

3"-12" SF150/SF300 Exploded View

Repair Kits
Soft Parts
Item # 7, 8,
9, 10, 11, 12

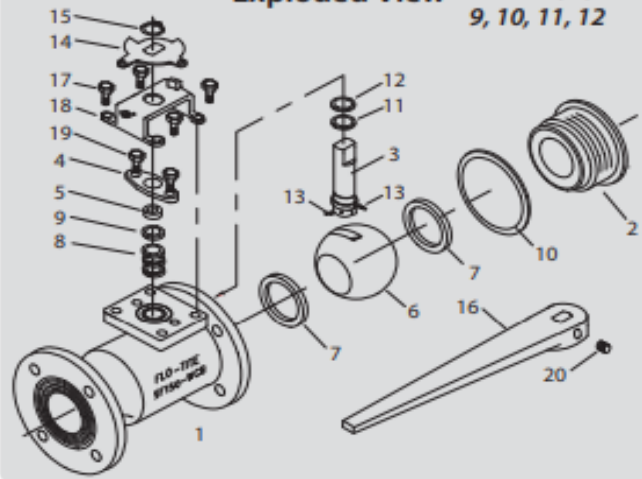

Optional live-loaded packing with belleville springs

Pressure Temperature Rating

These ratings are conservative guide for general service. Previous experience in process or new development may permit applications at ratings above those shown.

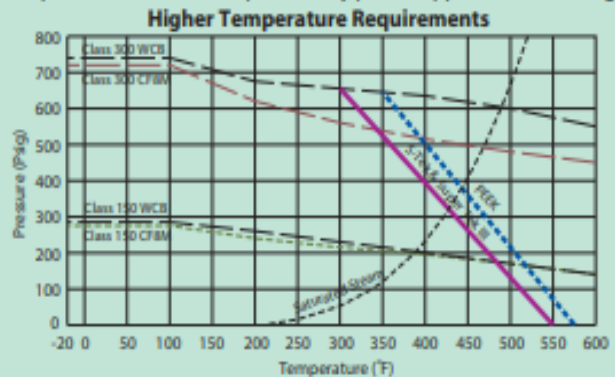
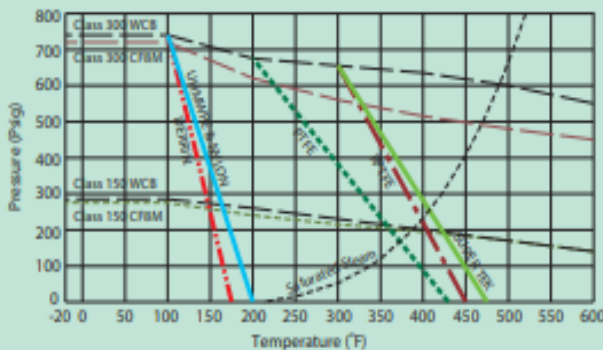

Saturated steam services above 150 psi use either Super Tek III or S-Tek. Saturated steam services above 250 psig use metal seats.
Metal Seated Ball Valve will take full ANSI body metal material ratings.

Dimensions - Reduced Bore

Technical Submittal

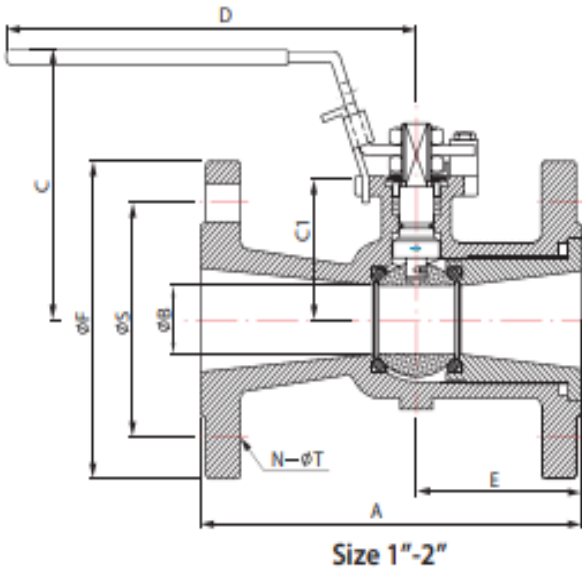

SF150/SF300 Series

New 2 pc body design - RF15 Consult Factory

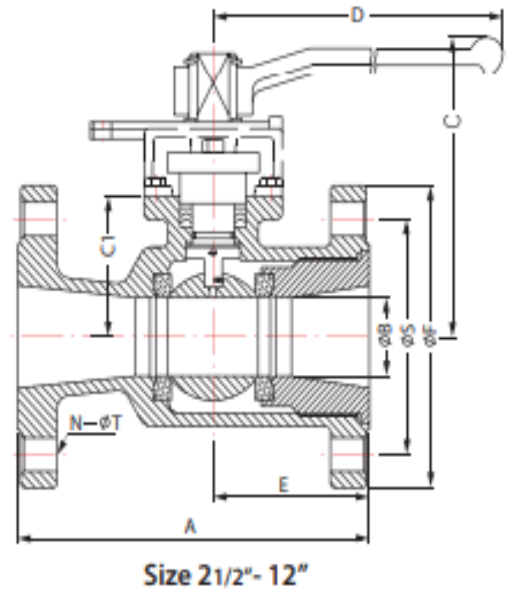

Model SF150 - ANSI Class 150

Size	A	B	C	C1	D	E	F	N	S	T	Cv	Torque in-lb	Est. Weight Lbs
1"	5.00	0.79	2.91	1.67	6.50	2.0	4.25	4	3.13	0.63	33	95	7
1 1/2"	6.50	1.26	3.62	2.20	7.87	2.17	5.00	4	3.88	0.63	85	252	12
2"	7.00	1.50	4.20	2.61	10.4	2.56	6.00	4	4.75	0.75	160	284	17
3"	8.00	2.56	6.22	3.78	15.4	3.0	7.50	4	6.00	0.75	340	651	38
4"	9.00	3.00	6.38	4.69	15.4	3.35	9.00	8	7.50	0.75	800	840	55
6"	10.5	4.00	6.52	4.33	15.4	4.61	11.0	8	9.50	0.87	1090	1785	80
8"	11.5	5.98	10.1	6.85	25.6	5.85	13.5	8	11.75	0.87	2300	4830	191
10"	13.0	7.87	11.6	7.62	37.4	6.85	16.0	12	14.25	1.00	4000	10395	315
12"	14.0	9.84	12.8	8.92	38.0	7.00	19.0	12	17.0	1.00	7700	17850	518

Mounting Dimensions (SF150/SF300)

Size	d	K	L	M	P	W	ISO
1"	1.65	0.43	0.59	0.250	0.37	#10-24UNC	F04
1 1/2"	1.97	0.43	0.75	0.315	0.43	1/4-20UNC	F05
2"	2.76	0.55	0.91	0.374	0.62	5/16-18UNC	F07
3"	4.02	1.31	2.59	0.669	1.10	1/2-13UNC	F10
4",6"	4.02	1.75	3.07	0.669	1.10	1/2-13UNC	F10
8",10"	4.92	1.65	3.58	1.024	1.71	1/2-13UNC	F12
12"	5.51	2.13	3.86	1.378	1.97	5/8-11UNC	F14

Model SF300 - ANSI Class 300

Size	A	B	C	C1	D	E	F	N	S	T	Cv	Torque in-lb	Est. Weight Lbs
1"	6.50	0.79	2.91	1.67	6.50	2.18	4.88	4	3.50	0.75	33	100	9
1 1/2"	7.50	1.26	3.62	2.20	7.87	2.60	6.14	4	4.50	0.87	85	265	18
2"	8.50	1.50	4.13	2.61	10.4	2.92	6.50	8	5.00	0.75	160	298	25
3"	11.14	2.24	6.77	3.78	15.4	3.75	8.27	8	6.62	0.87	340	684	56
4"	12.0	3.15	7.68	4.69	15.4	3.86	10.0	8	7.87	0.87	800	882	75
6"	15.87	3.94	7.52	4.33	15.4	4.61	12.5	12	10.63	0.87	1090	1874	133
8"	16.5	5.91	10.1	6.85	25.6	5.85	15.0	12	13.0	1.00	2300	5072	303
10"	18.0	7.87	11.6	7.62	37.4	6.85	17.5	16	15.25	1.14	4000	10915	464
12"	19.75	9.53	13.7	8.92	38.0	7.00	20.5	16	17.75	1.25	7700	18743	818

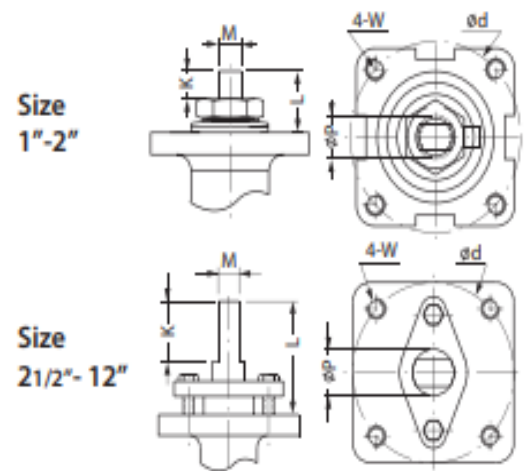

* Verify mounting dimensions before manufacturing mounting hardware



Please carefully review all important procedures in this manual. If anything is unclear, please feel free to contact Flo-Tite directly.



Flo-Tite, Inc.
4815 West 5th St.
Lumberton, NC 28358

P. O. Box 1293
Lumberton, NC 28359
Website: www.maxsealinc.com

Tel: (910) 738-8904
Fax: (910) 738-9112
E-mail: sales@maxsealinc.com