



Flanged / Wafer Full Bore Ball Valve

Kompact Series

A Compact Valve designed for applications where space & weight are of major concern



Models:
W150SS / W150CS



Pressure Rating:
Class 150

Materials:
316 Stainless Steel
Carbon Steel

Temperature Range:
Consult Factory

Size Range:
1/4" - 6"

Kompact Series
STANDARD PRODUCT NUMBER
W150-SS-FF-L (SS Standard)
W150-CS-FF-L (CS Standard)
W150-SS-CFF-L (SS Cavity filler)
W150-CS-CFF-L (CS Cavity filler)
C/F For price with cavity filler

**Ideal Ball Valve for
OEM Applications**

Design Features:

- The valve body is tapped allowing use of cap screws to install valve between ANSI 150 LB flanges

Optional

- ISO 5211 Direct Mount Design
- Pocketless design supplied with cavity fillers

Ideal Design for Control Valve

- Compact Control Package
- Economical low operating cost
- Characterized linear, V, or slotted ball design to meet your custom flow requirements

• Full Port Design

• Blow-out Proof Stem Design

• Double "D" Stem 1/2"-4"; 6" Square

• Foundry Heat Numbers

• ISO 5211 Mounting Pad

• Super-Tek Seating

• Low-Torque Design

• Live-loaded stem design

The Kompact Series is ideal for control, modulating, and many other applications that specially require low profile valves.

www.flotite.com

Design & Technical Data

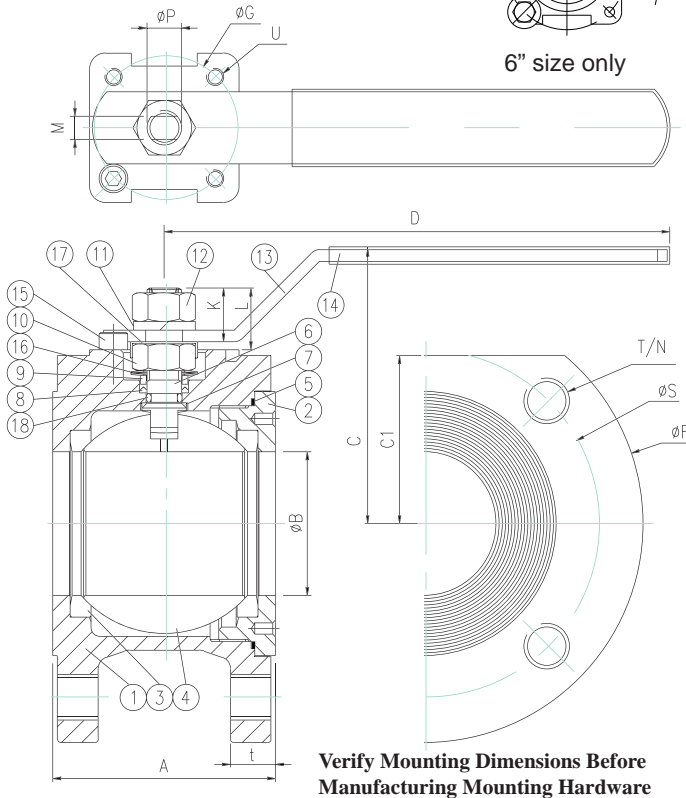

Flo-Tite's Kompact Wafer Series is an ideal choice for Control Valve applications.

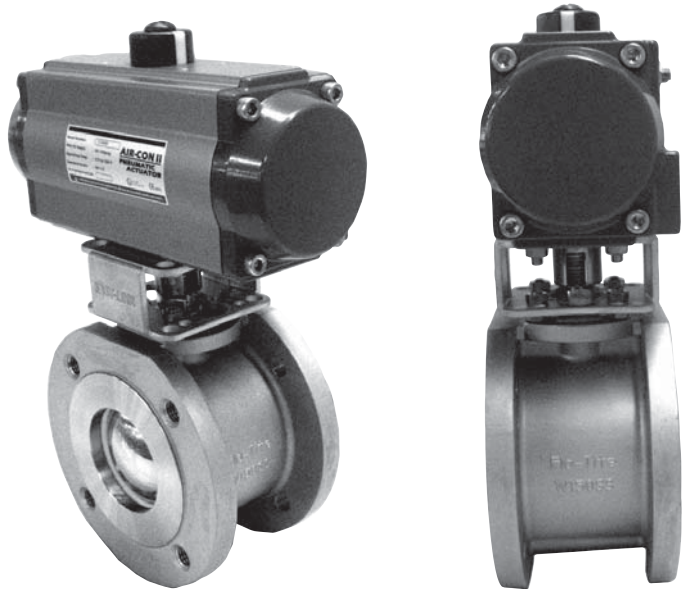

3" Valve

4.57" wide

Valuable Space Saving Compact Design

Dimensions & Technical Data

SIZE	A	B	C	C1	D	F	G	K	L	M	N	P	S	t	T	ISO Pad	U	Cv	Torque In-Lb	Weight Lbs
1/2"	1.61	0.63	2.56	0.70	4.84	3.78	1.42	0.39	0.66	0.26	4	0.39	2.37	0.55	1/2-13unc	F03	M5	15	58	3.2
3/4"	1.77	0.79	2.72	0.74	4.84	4.13	1.42	0.39	0.68	0.26	4	0.39	2.75	0.63	1/2-13unc	F03	M5	40	80	3.7
1"	2.13	0.98	3.15	1.75	6.22	4.53	1.65	0.63	0.99	0.34	4	0.55	3.13	0.63	1/2-13unc	F04	M5	70	108	6.6
1 1/4"	2.28	1.26	3.43	2.01	6.22	5.31	1.65	0.63	0.94	0.34	4	0.55	3.50	0.63	1/2-13unc	F04	M5	120	150	7.9
1 1/2"	2.44	1.50	3.78	2.17	7.80	5.71	1.97	0.83	1.15	0.39	4	0.63	3.87	0.63	1/2-13unc	F05	M6	200	200	8.8
2"	3.05	1.97	3.76	2.38	6.89	6.00	1.97	0.70	0.85	0.31	4	0.47	4.75	0.62	5/8-11unc	F05	M6	480	300	11
3"	4.57	2.99	5.71	3.46	9.57	7.50	2.76	0.77	1.50	0.47	4	0.75	6.00	0.75	5/8-11unc	F07	M8	1150	750	26
4"	5.91	3.78	6.59	4.49	11.22	8.66	2.76	1.01	1.32	0.47	8	0.75	7.50	0.94	5/8-11unc	F07	M8	1850	1000	44
6"	7.17	5.31	8.46	6.34	18.11	11.0	4.02	1.05	1.20	0.87	8	1.10	9.50	1.00	3/4-10unc	F10	0.43	4800	2018	84

Larger Sizes On Application: Consult Factory

Pressure & Temperature Rating:

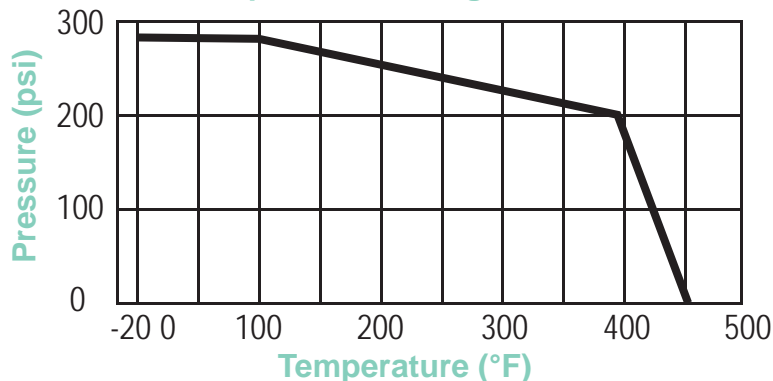

Technical Specifications	
Body Wall Thickness	ASME B16.34
Body Bolting	ASME B16.34
Testing Standards	ASME B16.34, API 598
NACE	MR-0175
Manufacturing	CE Certified / ISO 9001

All Valves are 100% Hydrostatically Pressure Tested in Open and Closed Positions.

Class 150 Test Pressure:

Shell 425 Psi

Seat 80 Psi (air)



Kompact Series Wafer Type Ball Valve

Models:

Stainless Steel
Carbon Steel

W 150-SS
W 150-CS

Exploded View

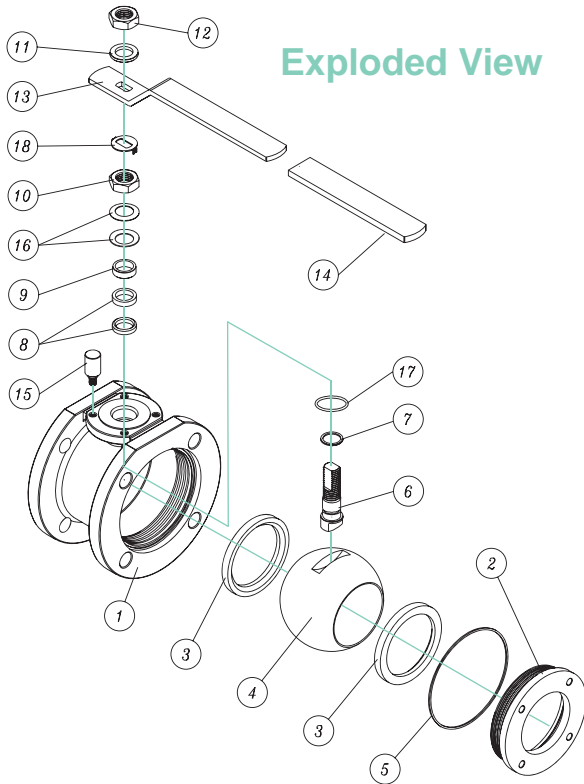

BILL OF MATERIALS:

Item	Parts	W150SS	W150CS	Qty
1	Body	ASTM A351 CF8M	ASTM A216 WCB	1
2	Retainer	ASTM A351 CF8M	ASTM A216 WCB	1
3	Seats #	TFM1600/Super-Tek	TFM1600/Super-Tek	2
4	Ball	ASTM A351 CF8M	ASTM A351 CF8	1
5	Gasket #	TFM1600	TFM1600	1
6	Stem	17-4PH	17-4PH	1
7	Thrust Washer #	25% Carbon Filled PTFE	25% Carbon Filled PTFE	1
8	Stem Packings #	TFM1600	TFM1600	3
9	Packing Follower	SS304	SS304	1
10	Packing Nut	SS304	SS304	1
11	Handle Washer	SS304	SS304	1
12	Handle Nut	SS304	SS304	1
13	Handle	SS304	Zinc Plated Steel	1
14	Handle Cover	PVC	PVC	1
15	Handle Stopper	SS304	Carbon Steel	1
16	Belleville Washers	SS301	SS301	2
17	Lock Washer	SS304	SS304	1
18	O-Ring #	Viton	Viton	1

Parts included in the repair kits

Special body materials are also available

Unique Low-Torque Design

- Precision dimensions with very tight tolerance
- Exact compression of ball seats
- Stop/step for seat retainer does not allow for over tightening in assembly process
- Low-torque stem design: high polish, the blow-out proof stem shoulder has a 45° bell shaped slope
- V-Ring live-loaded stem packing
- Valve ball is precisely machined and polished: spherically plus/minus 0.0008", surface finish 4 microinches roughness average
- Super-Tek TFM seats provide a wide temperature range without using fillers, but with lower torques as compared to RPTFE.
- Torque-approximately 20% less than other conventional full port valves. This reduced torque allows the use of smaller actuators and mounting kits, providing lower profile and lower prices.

Straight Through Flow

All flow is directed through the ball orifice. Full body cavity fillers prevent flow from diverting behind or around the valve ball. This unique design results in a more efficient linear flow stream. The narrow wafer body is very close to the ball's overall width.

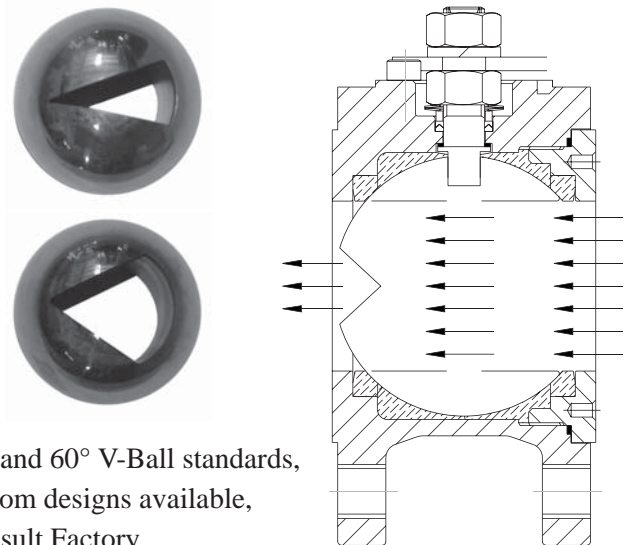

30° and 60° V-Ball standards,
custom designs available,
Consult Factory.

Dimensions

NOTE:
Similar actuators are available in our 4-piston design compact series

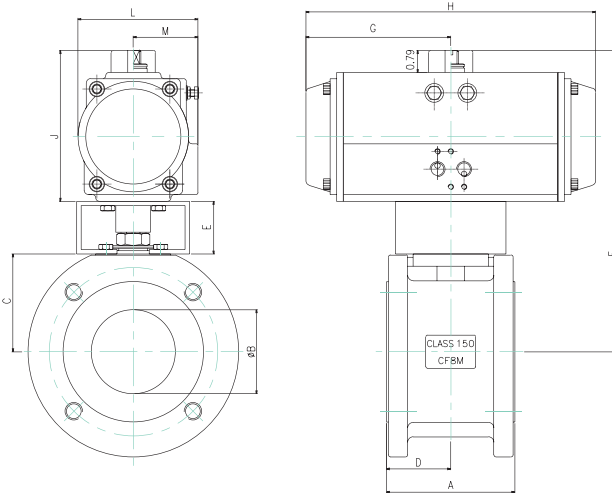

Pneumatic Actuator Dimensions shown in this drawing are for units based on 60 or 80 psi supply air, valves with standard seats, clean fluid at ambient temperature & pressures not to exceed 250 psi. Consult factory for additional actuator types and dimensional drawings.

Wafer Valve with Double Acting Actuator

SIZE	DOUBLE ACTING 80 PSI												DOUBLE ACTING 60 PSI						
	A	B	C	D	E	Actuator	F	G	H	J	L	M	Actuator	F	G	H	J	L	M
2"	3.05	1.97	2.38	1.52	1.87	C-DA063	8.49	3.31	6.61	4.23	3.27	1.85	C-DA075	8.96	3.62	7.24	4.70	3.74	2.09
3"	4.57	2.99	3.54	2.28	1.87	C-DA092	10.75	5.16	10.31	5.39	4.27	2.30	C-DA092	10.75	5.16	10.31	5.39	4.27	2.30
4"	5.91	3.78	4.49	2.95	1.87	C-DA092	11.76	5.16	10.31	5.39	4.27	2.30	C-DA105	12.39	5.28	10.55	6.02	4.78	2.52
6"	7.17	5.31	5.12	3.58	0	C-DA125	13.23	5.83	11.65	6.89	5.59	2.93	C-DA140	13.88	7.68	15.35	7.54	5.98	3.03

Wafer Valve with Spring Return Actuator

SIZE	SPRING RETURN 80 PSI												SPRING RETURN 60 PSI						
	A	B	C	D	E	Actuator	F	G	H	J	L	M	Actuator	F	G	H	J	L	M
2"	3.05	1.97	2.38	1.52	1.87	C-SR083.12	9.33	4.02	8.03	5.07	4.05	2.24	C-SR092.8	9.65	5.16	10.31	5.39	4.27	2.30
3"	4.57	2.99	3.54	2.28	1.87	C-SR105.12	11.38	5.28	10.55	6.02	4.78	2.52	C-SR125.8	12.25	5.83	11.65	6.89	5.59	2.93
4"	5.91	3.78	4.49	2.95	1.87	C-SR125.12	13.26	5.83	11.65	6.89	5.59	2.93	C-SR140.8	13.91	7.68	15.35	7.54	5.98	3.03
6"	7.17	5.31	5.12	3.58	0	C-SR140.12	13.88	7.68	15.35	7.54	5.98	3.03	C-SR160.8	14.88	9.02	18.03	8.54	6.86	3.43

For size 1/2"-1 1/2", please consult factory

Important Design Features and Benefits

- Weight - 30% less weight than other conventional full port valves, ideal for transportation vehicles, boats, planes, trains and many other applications where weight is of major concern
- Price - significantly less than other conventional full port valves
- Pocketless design 2"-6" are available with full PTFE body cavity fillers. Many valve users will not use ball valves due to the dead space behind valve ball. The compact valve is also ideal for asphalt applications within the temperature limits of the valve trim
- Uni-body construction - one piece body design eliminates the possibility of body seal leaks; adds strength to the pipeline
- Steam jacket design - the one piece body design offers ease of adding weld-on jackets
- Tank Bottom - Compact design is ideal where space is limited like undertanks, and near floors, with very little "dead space" between valve ball and flanged end.
- Control Valves - body flanges are tapped, uses cap screws to install, the valve is held in the pipeline better than most other conventional flanged end valve designs. This design allows for dead end service.



Flo-Tite, Inc.
4815 West 5th St.
Lumberton, NC 28358

P. O. Box 1293
Lumberton, NC 28359
Website: www.flotite.com

Tel: (910) 738-8904
Fax: (910) 738-9112
E-mail: flotite@flotite.com

Due to continuous development & improvement of our product range, we reserve the right to alter the dimensions and technical data included in this brochure.