



**CAUTION:**  
Compressed spring in the cylinder has strong retightening force. It is prohibited to detach covers from both ends of the cylinder in any case, otherwise personal injury may result. Dismantling and installation should be carried out by professional people, when malfunction and/or interruption occurs.

# Air-Max ACTUATOR



## WORKING CONDITIONS

**MEDIUM:** Clean, dry compressed air or erosion-free gas.

**AIR SUPPLY RANGE:** 5 to 7 bar

**STANDARD TEMPERATURE RANGE:** -20° C to 80° C

**TRAVEL STROKE ADJUSTABLE RANGE:**  $\pm 5^\circ$  of the travel stop of the 90° or 0° position.

**LUBRICATION:** No need to lubricate the actuator under normal operating conditions.

**INSTALLATION:** IP 67 rating makes Linuo actuators suitable for installation indoors or out

### DESIGNATIONS:

ZSQ = Double Acting Actuator

ZDBQ = Spring Return, Fail Open, Heavy Spring

ZDBLQ = Spring Return, Fail Open, Light Spring

ZDAQ = Spring Return, Fail Close, Heavy Spring

ZDALQ = Spring Return, Fail Close, Light Spring

**CONVERSIONS:** It should be noted that double acting actuators may not be converted to spring return actuators, or vice versa. It is also not possible to convert a fail close actuator to fail open. For ball valve applications or butterfly valves that allow 360° rotation, a fail close actuator may be used for fail open application by rotating the mounting 90° when specified at confirmation of order

**ACCESSORIES:** Linuo actuators are suitable for both on/off applications and control applications. Standard ISO mounting pads provided on the actuators allow for easy installation of limit switches or positioners.

## PRINCIPLE OF OPERATION

The force of air or springs on the piston, causes linear motion of the piston. The connecting linkage converts this linear motion into 90° rotation of the lever arm. The effective arm of force of the actuator changes during the rotary motion, resulting in corresponding variable torque outputs. See the table below. In the table, it shows that the maximum torque output value is achieved at 0°, at which generally ball or butterfly valves require the most torque, to close the valve. Another peak can be seen at approximately 75°. This corresponds to the peak value of dynamic torque requirement for butterfly valves.

$\alpha = 0^\circ$  Valve is CLOSED

$\alpha = 90^\circ$  Valve is OPEN

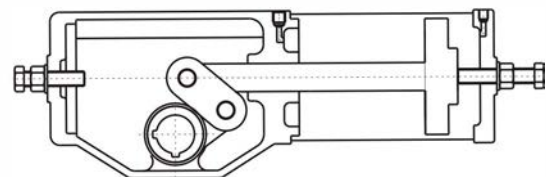
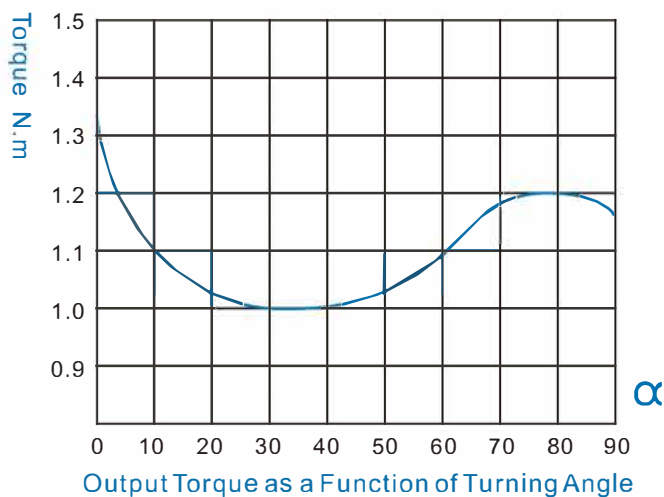

$\alpha = 0^\circ$  Valve is CLOSED

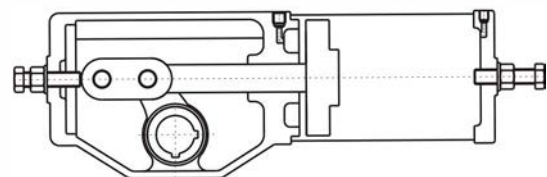

$\alpha = 90^\circ$  Valve is OPEN



## Design Features and Benefits

- Smaller size and weight with high thrust capabilities.
- Enhanced control and responsiveness.
- Smaller air volumes allows for faster response providing quick opening/closing speeds.
- Stable performance for valves in applications with high pressure drop conditions.
- Rugged compact heavy duty construction
- Durability, reliability, and ultimately, low maintenance cost.
- Flexible design and construction of the stroke length, fail-safe mechanism, and manual override system provide users with an optimized actuation solution to meet a large variety of requirements.
- Piston Actuators typically provide longer strokes and higher thrusts compared to spring-diaphragms.

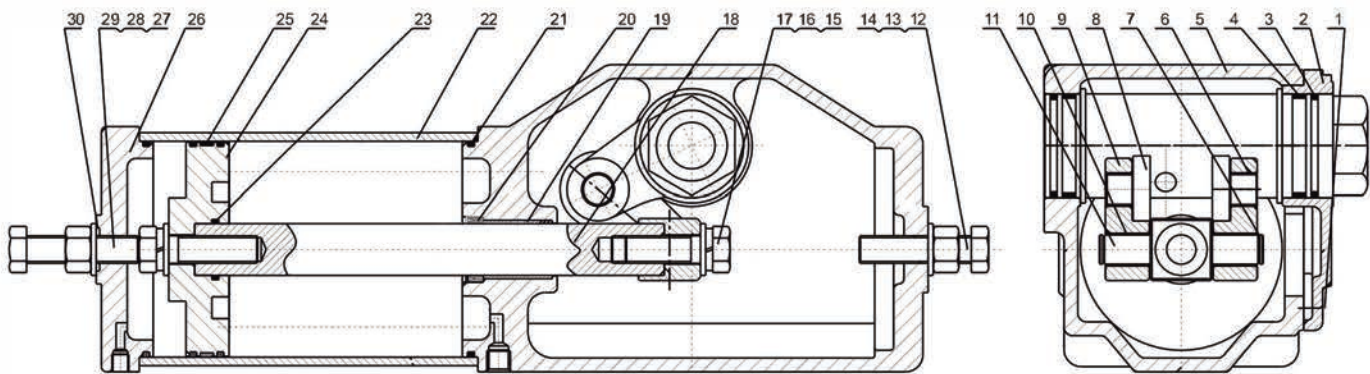

### PARTS LIST OF ZSQ DOUBLE ACTING ACTUATOR

No.	Description	Qty	Material	No.	Description	Qty	Material
1	Screw	4	Stainless Steel	16	Spring Washer	1	Spring Steel
2	Cover	1	Aluminum or Steel	17	Washer	1	Stainless Steel
3	O-Ring	2	NBR	18	Piston Rod	1	45# Steel + Cr
4	Pinion Guide Bearing	2	Reinforced PTFE	19	Boundary Lube Bearing	1	Composite Plastic
5	Housing	1	Aluminum or Steel	20	Y-Ring	1	Rubber
6	Boundary Lube Bearing	2	Composite Plastic	21	O-Ring	2	NBR
7	Retaining Ring	2	Spring Steel	22	Cylinder	1	Alum Alloy/Steel + Cr
8	Lever Arm	1	Cast Iron	23	O-Ring	1	NBR
9	Connecting Arm	1	Steel	24	Piston	1	Aluminum Alloy
10	Boundary Lube Bearing	2	Composite Plastic	25	Guide Bearing	1	Reinforced PTFE
11	Cardan Shaft	1	45# Steel	26	Cylinder End	1	Cast Steel
12	Travel Stop Bolt	1	Stainless Steel	27	Bolt	1	Stainless Steel
13	Nut	1	Stainless Steel	28	Nut	1	Stainless Steel
14	Washer	1	Stainless Steel	29	Washer	1	Stainless Steel
15	Bolt	1	Stainless Steel	30	Gasket	1	PTFE



## Pneumatic Piston Actuators

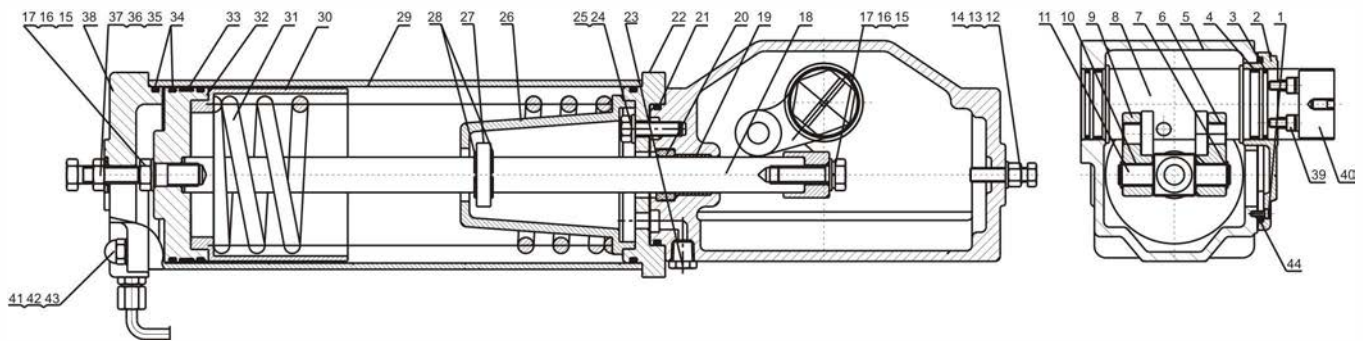

## PARTS LIST OF ZDQ SPRING RETURN ACTUATOR

No.	Description	Qty	Material	No.	Description	Qty	Material
1	Screw	4	Stainless Steel	23	Muffler	1	Steel
2	Cover	1	Aluminum or Steel	24	Bolt	4	Stainless Steel
3	O-Ring	2	NBR	25	Washer	4	Stainless Steel
4	Pinion Guide Bearing	2	Reinforced PTFE	26	Rear Spring Seat	1	Steel
5	Housing	1	Aluminum or Steel	27	Spring Retainer	1	Steel
6	Boundary Lube Bearing	2	Composite Plastic	28	Spring Retaining Ring	2	Spring Steel
7	Retaining Ring	2	Spring Steel	29	Cylinder	1	Alum Alloy / Steel + Cr
8	Lever Arm	1	Cast Iron	30	Spring Guide Bushing	1	Steel
9	Connecting Arm	2	Steel	31	Spring	1	Spring Steel
10	Boundary Lube Bearing	2	Composite Plastic	32	Piston	1	Aluminum Alloy
11	Cardan Shaft	1	45# Steel	33	Guide Bearing	1	Reinforced PTFE
12	Nut	1	Stainless Steel	34	O-Ring	4	NBR
13	Travel Stop Bolt	1	Stainless Steel	35	Gasket	1	PTFE
14	Washer	1	Stainless Steel	36	Nut	1	Stainless Steel
15	Washer	1	Stainless Steel	37	Travel Stop Bolt	1	Stainless Steel
16	Spring Washer	1	Spring Steel	38	Cylinder End	1	Cast Steel
17	Bolt	1	Stainless Steel	39	Screw	4	Stainless Steel
18	Piston Rod	1	45# Steel + Cr	40	Lever Arm End	1	Stainless Steel
19	Boundary Lube Bearing	1	Composite Plastic	41	Bolt Stud	4	45# Steel + Zn
20	Y-Ring	1	Rubber	42	Nut	4	Stainless Steel
21	O-ring	1	NBR	43	Washer	4	Stainless Steel
22	Filter Flange	1	Cast Steel	44	Waterproof Gasket	1	Rubber



## ZSQ DOUBLE ACTING ACTUATOR TORQUE

Model	Torque Output in N·m at Specified Supply Pressure in bar			
	4 bar	5 bar	6 bar	7 bar
ZSQ32-63	32	40	48	56
ZSQ41-80	64	80	96	112
ZSQ41-100	100	125	150	180
ZSQ41-125	156	195	234	280
ZSQ50-100	120	150	180	210
ZSQ50-125	192	240	288	336
ZSQ50-160	314	390	470	550
ZSQ60-125	262	290	392	458
ZSQ60-160	392	490	588	680
ZSQ60-200	588	735	882	1030
ZSQ80-200	784	980	1176	1370
ZSQ80-250	1224	1530	1836	2140
ZSQ100-300	2160	2700	3240	3780
ZSQ130-300	2880	3600	4320	5040
ZSQ130-350	3920	4900	5880	6860
ZSQ130-400	5080	6350	7620	8890
ZSQ160-400	6900	8600	10300	12000
ZSQ160-450	8600	10890	13000	15000

## ZDLQ AND ZDQ SPRING RETURN ACTUATOR TORQUE

Model	Spring Minimum Torque N·m	Torque Output in N·m at Specified Supply Pressure in bar				
		2.5 bar	4 bar	5 bar	6 bar	7 bar
ZDLQ41-100	39	22	37	54	72	
ZDQ41-100	50		25	43	60	78
ZDLQ41-125	62	33	58	85	112	
ZDQ41-125	82		33	60	86	115
ZDLQ50-125	80	40	70	104	137	
ZDQ50-125	100		40	73	105	140
ZDLQ50-160	130	65	115	170	225	
ZDQ50-160	160		80	135	190	240
ZDLQ60-160	155	80	135	200	265	
ZDQ60-160	195		95	160	220	290
ZDLQ60-200	250	110	200	300	400	
ZDQ60-200	300		125	265	330	430
ZDLQ80-200	340	146	265	400	533	
ZDQ80-200	400		167	353	440	573
ZDLQ80-250	530	230	415	625	830	
ZDQ80-250	620		270	485	700	910
ZDLQ80-300	780	310	575	885	1190	
ZDQ80-300	930		420	725	1035	1340
ZDLQ100-300	970	370	700	1080	1450	
ZDQ100-300	1170		490	875	1260	1640
ZDLQ130-350	1725	671	1250	1940	2620	
ZDQ130-350	2000		900	1600	2270	2900
ZDLQ130-400	2300	830	1600	2500	3380	
ZDQ130-400	2700		1120	2010	2900	3800
ZDLQ160-400	2700	1300	2340	3500	4750	
ZDQ160-400	3630		1240	2440	3654	4860
ZDLQ160-450	3630	1800	3100	4600	6170	
ZDQ160-450	4500		1600	3160	4690	6200





Pneumatic Piston Actuators

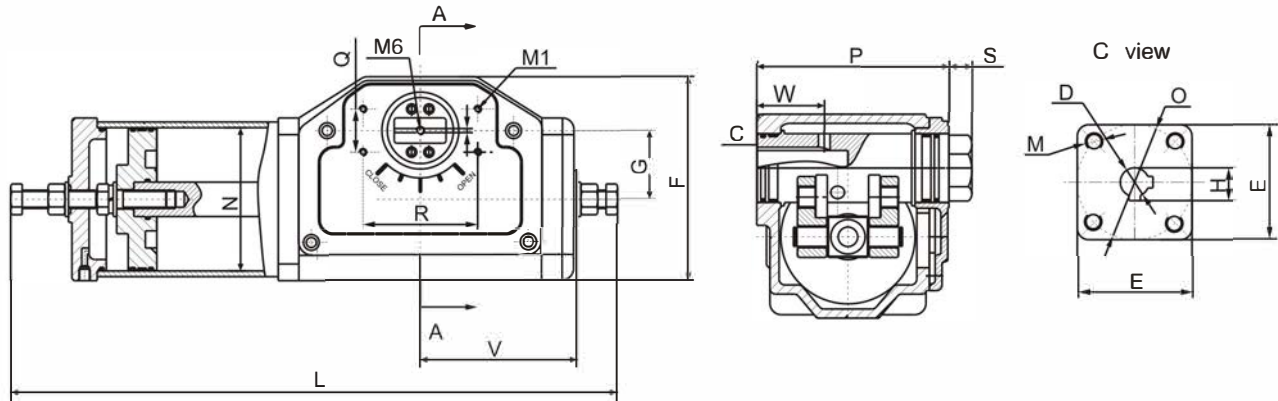

ZSQ DOUBLE ACTING ACTUATOR DIMENSIONS (mm)

Model	ØN	L	V	G	F	P	W	S	ØO	ØD	H	M	E	R	Q	M1
ZSQ32-63-16	63.00	330.00	110.00	32.00	106.00	102.00	50.00	20.00	60.00	16.00	18.30	4-M8	64.00	80.00	30.00	4-M5
ZSQ41-80-16	80.00	408.00	135.00	41.00	125.00	122.00	60.00	20.00	60.00	16.00	18.30	4-M8	70.00	80.00	30.00	4-M5
ZSQ41-100-20	100.00	436.00	135.00	41.00	125.00	122.00	60.00	20.00	60.00	20.00	22.80	4-M8	70.00	80.00	30.00	4-M5
ZSQ41-125-20	125.00	436.00	135.00	41.00	125.00	122.00	60.00	20.00	60.00	20.00	22.80	4-M8	70.00	80.00	30.00	4-M5
ZSQ50-100-20	100.00	450.00	150.00	50.00	151.00	132.00	60.00	20.00	75.00	20.00	22.80	4-M8	86.00	80.00	30.00	4-M5
ZSQ50-125-25	125.00	494.00	150.00	50.00	151.00	132.00	60.00	20.00	75.00	25.00	28.30	4-M8	86.00	80.00	30.00	4-M5
ZSQ50-160-30	160.00	550.00	150.00	50.00	151.00	132.00	60.00	20.00	75.00	30.00	33.30	4-M8	86.00	80.00	30.00	4-M5
ZSQ60-125-30	125.00	583.00	174.00	60.00	178.00	168.00	70.00	20.00	85.00	30.00	33.30	4-M10	100.00	80.00	30.00	4-M5
ZSQ60-160-40	160.00	583.00	174.00	60.00	178.00	168.00	70.00	20.00	85.00	40.00	43.30	4-M10	100.00	80.00	30.00	4-M5
ZSQ60-200-40	200.00	583.00	174.00	60.00	178.00	168.00	70.00	20.00	85.00	40.00	43.30	4-M10	100.00	80.00	30.00	4-M5
ZSQ80-200-40	200.00	773.00	247.00	80.00	230.00	202.00	85.00	30.00	120.00	40.00	43.30	4-M16	150.00	130.00	30.00	4-M5
ZSQ80-200-45	200.00	773.00	247.00	80.00	230.00	202.00	85.00	30.00	120.00	45.00	48.80	4-M16	150.00	130.00	30.00	4-M5
ZSQ80-250-50	250.00	773.00	247.00	80.00	230.00	202.00	85.00	30.00	120.00	50.00	54.30	4-M16	150.00	130.00	30.00	4-M5
ZSQ80-250-55	250.00	773.00	247.00	80.00	230.00	202.00	85.00	30.00	120.00	55.00	59.30	4-M16	150.00	130.00	30.00	4-M5
ZSQ100-300-40	300.00	892.00	273.00	100.00	280.00	216.00	85.00	30.00	165.00	40.00	43.30	4-M20	171.00	130.00	30.00	4-M5
ZSQ100-300-45	300.00	892.00	273.00	100.00	280.00	216.00	85.00	30.00	165.00	45.00	48.80	4-M20	171.00	130.00	30.00	4-M5
ZSQ100-300-50	300.00	892.00	273.00	100.00	280.00	216.00	85.00	30.00	165.00	50.00	54.30	4-M20	171.00	130.00	30.00	4-M5
ZSQ100-300-55	300.00	892.00	273.00	100.00	280.00	216.00	85.00	30.00	165.00	55.00	59.30	4-M20	171.00	130.00	30.00	4-M5
ZSQ130-300-50	300.00	1015.00	365.00	130.00	335.00	258.00	125.00	30.00	175.00	50.00	54.30	4-M20	180.00	130.00	30.00	4-M5
ZSQ130-350-60	350.00	1165.00	365.00	130.00	335.00	258.00	125.00	30.00	175.00	60.00	64.30	4-M20	180.00	130.00	30.00	4-M5
ZSQ130-400-70	400.00	1165.00	365.00	130.00	335.00	258.00	125.00	30.00	175.00	70.00	74.90	4-M20	180.00	130.00	30.00	4-M5
ZSQ130-400-80	400.00	1165.00	365.00	130.00	335.00	258.00	125.00	30.00	175.00	80.00	83.80	4-M20	180.00	130.00	30.00	4-M5
ZSQ160-400-70	400.00	1200.00	390.00	160.00	417.00	318.00	170.00	30.00	252.00	70.00	74.90	8-M20	271.8/266.7	240.00	40.00	4-M8
ZSQ160-450-80	450.00	1200.00	390.00	160.00	417.00	318.00	170.00	30.00	252.00	80.00	85.40	8-M20	271.8/266.7	240.00	40.00	4-M8

ZDQ SPRING RETURN ACTUATOR DIMENSIONS (mm)

Model	ØN	L	V	G	F	P	W	S	ØO	ØD	H	M	E	R	Q	M1
ZDQ41-100-16	100.00	560.00	135.00	41.00	125.00	122.00	60.00	20.00	60.00	16.00	18.30	4-8M	70.00	80.00	30.00	4-M5
ZDQ41-125-20	125.00	590.00	135.00	41.00	125.00	122.00	60.00	20.00	60.00	20.00	22.80	4-8M	70.00	80.00	30.00	4-M5
ZDQ50-125-20	125.00	670.00	150.00	50.00	153.00	132.00	60.00	20.00	75.00	20.00	22.80	4-8M	86.00	80.00	30.00	4-M5
ZDQ50-160-25	160.00	705.00	150.00	50.00	143.00	132.00	60.00	20.00	75.00	25.00	28.30	4-8M	86.00	80.00	30.00	4-M5
ZDQ50-160-30	160.00	705.00	150.00	50.00	143.00	132.00	60.00	20.00	75.00	30.00	33.30	4-8M	86.00	80.00	30.00	4-M5
ZDQ60-160-30	160.00	775.00	174.00	60.00	178.00	168.00	70.00	20.00	85.00	30.00	33.30	4-10M	100.00	80.00	30.00	4-M5
ZDQ60-200-40	200.00	820.00	174.00	60.00	178.00	168.00	70.00	20.00	85.00	40.00	43.30	4-10M	100.00	80.00	30.00	4-M5
ZDQ80-200-40	200.00	970.00	247.00	80.00	239.00	202.00	85.00	30.00	120.00	40.00	43.30	4-16M	150.00	130.00	30.00	4-M5
ZDQ80-250-30	300.00	995.00	247.00	80.00	239.00	202.00	85.00	30.00	120.00	30.00	33.30	4-16M	150.00	130.00	30.00	4-M5
ZDQ80-250-40	300.00	995.00	247.00	80.00	239.00	202.00	85.00	30.00	120.00	40.00	43.30	4-16M	150.00	130.00	30.00	4-M5
ZDQ80-250-45	250.00	995.00	247.00	80.00	239.00	202.00	85.00	30.00	120.00	45.00	48.80	4-16M	150.00	130.00	30.00	4-M5
ZDQ80-300-50	300.00	1105.00	247.00	80.00	239.00	202.00	85.00	30.00	120.00	50.00	54.30	4-16M	150.00	130.00	30.00	4-M5
ZDQ80-300-55	300.00	1105.00	247.00	80.00	239.00	202.00	85.00	30.00	120.00	55.00	59.30	4-16M	150.00	130.00	30.00	4-M5
ZDQ100-300-40	300.00	1210.00	273.00	100.00	280.00	239.00	85.00	30.00	165.00	40.00	43.30	4-20M	171.00	130.00	30.00	4-M5
ZDQ100-300-45	300.00	1210.00	273.00	100.00	280.00	239.00	85.00	30.00	165.00	45.00	48.80	4-20M	171.00	130.00	30.00	4-M5
ZDQ100-300-50	300.00	1210.00	273.00	100.00	280.00	239.00	85.00	30.00	165.00	50.00	54.30	4-20M	171.00	130.00	30.00	4-M5
ZDQ100-300-55	300.00	1210.00	273.00	100.00	280.00	239.00	85.00	30.00	165.00	55.00	59.30	4-20M	171.00	130.00	30.00	4-M5
ZDQ130-350-50	350.00	1430.00	365.00	130.00	344.00	308.00	125.00	30.00	175.00	50.00	54.30	4-20M	180.00	130.00	30.00	4-M5
ZDQ130-350-60	350.00	1430.00	365.00	130.00	344.00	308.00	125.00	30.00	175.00	60.00	64.30	4-20M	180.00	130.00	30.00	4-M5
ZDQ130-400-70	400.00	1495.00	365.00	130.00	344.00	308.00	125.00	30.00	175.00	70.00	74.90	4-20M	180.00	130.00	30.00	4-M5
ZDQ130-400-80	400.00	1495.00	365.00	130.00	344.00	308.00	125.00	30.00	175.00	80.00	85.40	4-20M	180.00	130.00	30.00	4-M5
ZDQ160-400-70	400.00	1625.00	390.00	160.00	417.00	318.00	170.00	30.00	252.00	70.00	74.90	8-20M	271.8/266.7	240.00	40.00	4-M8
ZDQ160-450-80	450.00	1635.00	390.00	160.00	417.00	318.00	170.00	30.00	252.00	80.00	85.40	8-20M	271.8/266.7	240.00	40.00	4-M8

## Pneumatic Piston Actuators



## AIR VOLUME AND WEIGHT

DA Model ZSQ	Air Volume Open (Outward) Stroke in Cubic m	Air Volume Close (inward) Stroke in Cubic m	Weight (kg)	Weight (lbs)
ZSQ32-63	0.34	0.32	6.25	13.78
ZSQ41-80	0.64	0.60	9.65	21.28
ZSQ41-100	1.04	1.00	11.90	26.24
ZSQ41-125	1.62	1.58	13.00	28.67
ZSQ50-100	1.19	1.13	16.00	35.28
ZSQ50-125	1.89	1.83	19.50	43.00
ZSQ50-160	3.38	3.32	28.00	61.74
ZSQ60-125	2.14	2.04	27.00	59.54
ZSQ60-160	3.76	3.66	37.20	82.03
ZSQ60-200	5.88	5.78	46.00	101.43
ZSQ80-200	7.68	7.50	75.00	165.38
ZSQ80-250	13.56	13.36	88.30	194.70
ZSQ100-300	20.43	20.07	191.00	421.16
ZSQ130-300	26.73	25.89	241.00	531.41
ZSQ130-350	37.36	36.50	270.00	595.35
ZSQ130-400	51.20	50.30	296.00	652.68
ZSQ160-400	63.20	62.09	392.00	864.36
ZSQ160-450	79.99	78.88	429.00	945.95

SR Model ZDLQ Light Spring	Air Volume Close (inward) Stroke in Cubic m	Weight (kg)	Weight (lbs)	SR Model ZDQ Heavy Spring	Air Volume Close (inward) Stroke in Cubic m	Weight (kg)	Weight (lbs)
ZDLQ41-100	2	37	81.59	ZDQ41-100	2	17	37.49
ZDLQ41-125	4	44	97.02	ZDQ41-125	4	20	44.10
ZDLQ50-125	5	64	141.12	ZDQ50-125	5	29	63.95
ZDLQ50-160	9	101	222.71	ZDQ50-160	9	46	101.43
ZDLQ60-160	9	123	271.22	ZDQ60-160	9	56	123.48
ZDLQ60-200	16	146	321.93	ZDQ60-200	16	67	147.74
ZDLQ80-200	21	227	500.54	ZDQ80-200	21	112	246.96
ZDLQ80-250	29	279	615.20	ZDQ80-250	29	135	297.68
ZDLQ80-300	44	372	820.26	ZDQ80-300	44	180	396.90
ZDLQ100-300	50	469	1034.15	ZDQ100-300	50	235	518.18
ZDLQ130-350	87	845	1863.23	ZDQ130-350	87	407	897.44
ZDLQ130-400	116	880	1940.40	ZDQ130-400	116	450	992.25
ZDLQ160-400	127	1214	2676.87	ZDQ160-400	127	607	1338.44
ZDLQ160-450	164	1362	3003.21	ZDQ160-450	164	672	1481.76

# How To Order

Actuator Type	Actuator Material	Housing Number	Cylinder Diameter	Shaft Diameter
<b>ZS</b>	<b>Q</b>	<b>41</b>	<b>100</b>	<b>20</b>
1	2	3	4	5

## Sign 1 Actuator Type

Code	ZS	ZDB	ZDA	ZDBL	ZDAL
Part	Pneumatic Double Acting	Pneumatic Single Acting(Spring to open, Heavy Spring)	Pneumatic Single Acting(Spring to close, Heavy Spring)	Pneumatic Single Acting (Spring to open, Light Spring)	Pneumatic Single Acting (Spring to close, Light Spring)

## Sign 2 Actuator Material

Code	Q	P	M
Material	Standard Material	CF8	CF8M

## Sign 3 Housing Number

Code	32	41	50	60	80	100	130	160
Diameter	32 Housing	41 Housing	32 Housing	60 Housing	80 Housing	100 Housing	130 Housing	160 Housing

## Sign 4 Cylinder Diameter(mm)

Code	63	80	125	160	200	250	300	350	400	450	500
Part	63	80	125	160	200	250	300	350	400	450	500

## Sign 5 Shaft Diameter

Code	16	20	25	30	35	40	45	50	55	60	70	80	90	100	Contact us for special request
Diameter	16	20	25	30	35	40	45	50	55	60	70	80	90	100	

Flo-Tite Valves and Controls

Add:4815 West 5th Street Lumberton, N.C

Tel:1(910)738-8904

Fax:1(910)738-9112

Email:sales@flotite.com <http://www.flotite.com>



FloTite Reserves The Rights To Change The Designs And Specifications Without Prior Notice.Please Consult FloTite For Details.