



Kingtron Series Petrochemical Applications

THREE-PIECE CLASS 2500 FORGED STEEL BALL VALVES

Model: S336 **Size Range:** 1/4" - 2" **Temperature Range:** -20° ~ 400°F **Maximum Pressures:** 6000 MAWP/WOG



Part ID'S
S336-LF-DGG-L-025
S336-CS-DGG-L-025

FEATURES:

- Forged steel body construction secures Class 2500/6000 psi working pressure rating.
- LF2 valve body & end caps for low-temperature applications.
- Special design of extended socket weld end facilitates heat dissipation during welding. No prior disassembly of valve is required, therefore welding installation process is shortened.
- Use of body O-ring and body joint gasket double secures **NO LEAKAGE**.
- Live-loaded packing gland for self-adjustment of stem packing compression.
- Rugged lockable lever handles for safety and long service life.
- Body O-rings are placed ahead of the body cap threads, providing a tight seal and protection of threads from flow media.
- Gland bolts allow for easy packing adjustment without handle removal.
- Pressure equalizing seats & bottom-loaded blow-out proof stems.
- Vented ball equalizes pressure between the body cavity and the flow stream to prevent seat damage due to thermal cycling.
- Full compliance with ASME/ANSI B16.34 & EN12516-1.
- Socket weld ends comply with ANSI B16.11 & EN 12760.
- Tested according to API 598.

Material List:

NO.	PARTS	S336-LF2	S336-A105	QTY
1	Body	ASTM A350-LF2	ASTMA105	1
2	End Cap	ASTM A350-LF2	ASTMA105	1
3	Seats #	PEEK	PEEK	2
4	Gaskets #	PTFE	PTFE	2
5	Ball	ASTM A351-CF8M/316	ASTM A351-CF8M/316	1
6	Thrust Washer #	PEEK	PEEK	1
7	Stem	ASTM A276-316	ASTM A276-316	1
8	Stem Packings #	PTFE	PTFE	set
9	Gland	AISI 304	AISI 304	1
10	Handle	Carbon Steel	Carbon Steel	1
11	Disc Washer	AISI 301	AISI 301	1
12	Handle Nut	Carbon Steel	Carbon Steel	1
13	Gland Flange	Carbon Steel	Carbon Steel	1
14	Gland Bolts	AISI 304	AISI 304	2
15	Body O-Rings #	VITON	VITON	2
16	Stem O-Ring #	VITON	VITON	1
17	Anti-Static	Stainless Steel	Stainless Steel	1

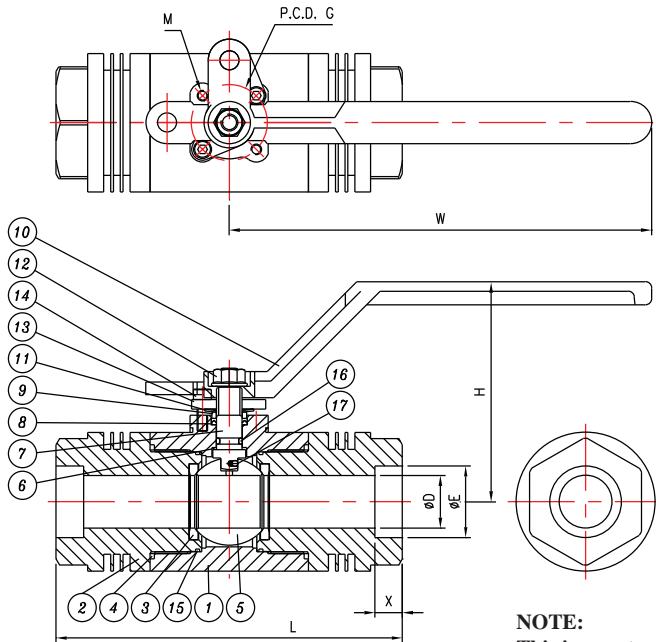

NOTE:
This is a custom order item. Consult factory for price and availability.

DIMENSIONS:

SIZE	D		E		G		H		L		M	W		X		Torque In-Lb	
	in	DN	in	mm	in	mm	in	mm	in	mm		in	mm	in	mm		
1/4"	8	0.37	9.5	0.56	14.2	1.42	36	3.15	80	4.61	117	M5	6.30	160	0.39	10	283
3/8"	10	0.37	9.5	0.69	17.6	1.42	36	3.15	80	4.61	117	M5	6.30	160	0.39	10	283
1/2"	15	0.49	12.5	0.86	21.8	1.42	36	3.15	80	4.61	117	M5	6.30	160	0.39	10	339
3/4"	20	0.79	20	1.07	27.2	1.42	36	3.90	99	5.99	152	M5	7.87	200	0.51	13	705
1"	25	0.98	25	1.33	33.9	1.42	36	4.09	104	6.46	164	M5	7.87	200	0.51	13	1137
1-1/2"	40	1.50	38	1.92	48.8	1.97	50	5.03	128	7.87	200	M6	9.84	250	0.51	13	2417
2"	50	1.50	38	2.41	61.2	1.97	50	5.03	128	8.07	205	M6	9.84	250	0.64	16.2	2550

OPTIONS:

- 17-4PH (ASTM A564 Type 630) Stem.
- F: Fire-safe per API 607, including graphite gasket, graphite stem packing, & post-fire metal-to-metal seal.
- HSN (HNBR) stem O-ring & body O-ring, PTFE body O-ring.
- Carbon 25% filled PTFE thrust washer, stem packing and gasket.

Parts included in the repair kits

Pressure-Temperature Ratings

