

MAX SEAL[®]
Valves & Controls

SEMI-LUG BUTTERFLY VALVES

Chem-Tek Series

Corrosion Resistant Stainless Steel Body

Models: 53
Size Range: 2" thru 12"

Pressure Rating
BUNA Seat: 200 WOG
EPDM Seat: 200 WOG
VITON Seat: 200 WOG
PTFE Seat: 150 WOG

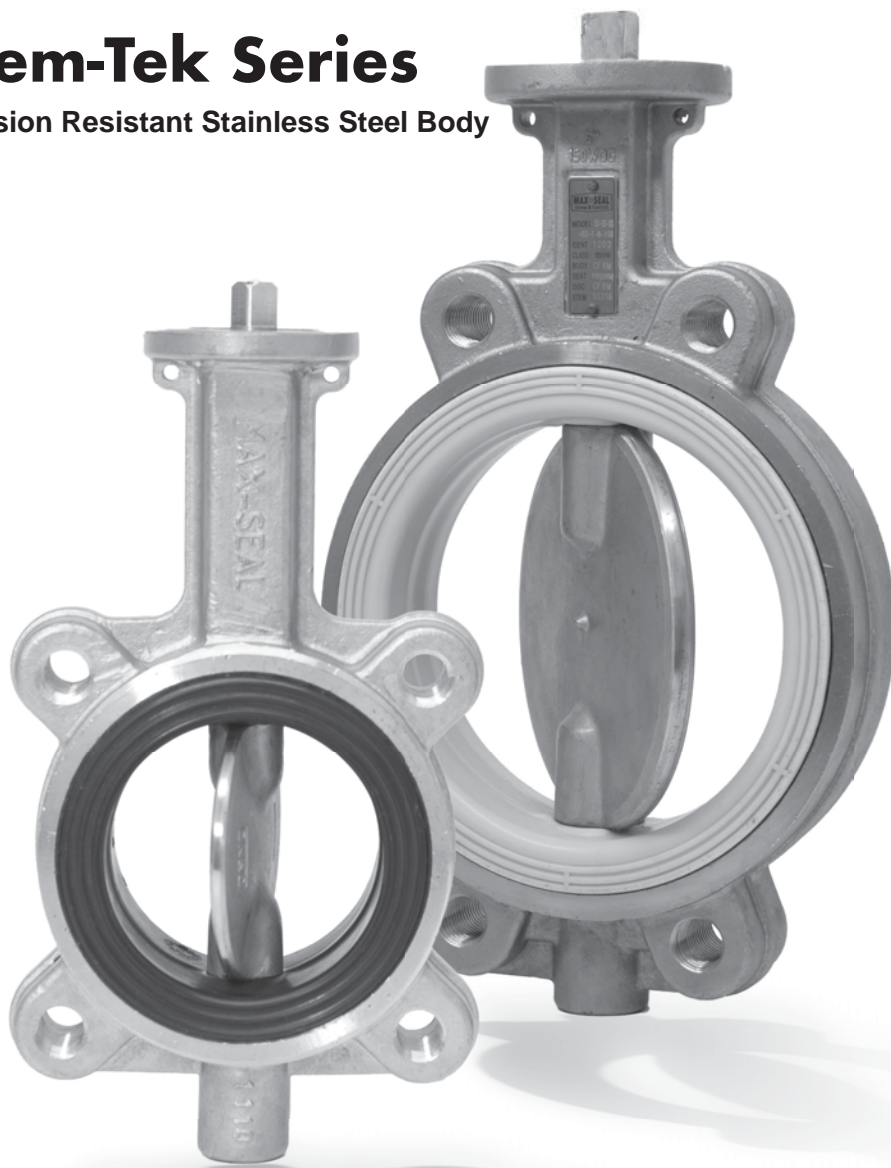

Max-Seal Concentric Butterfly Valves are backed by the resources and experience of over thirty-five years of process valve and automation experience

Design Advantages

- Semi-Lug Body Design Crossover from Wafer to Lug. All Valves Have Four Drilled and Tapped Lugs
- Ideal for Exact Alignment
- Lighter Weight than Full Lug Bodies
- Lower Cost than Full Lug Bodies
- Easy Assembly and Maintenance
- Ease of Maintenance as Valves can Remain in Piping Systems when One Side of the Piping is Removed

www.maxsealinc.com

MAX SEAL[®]
Valves & Controls

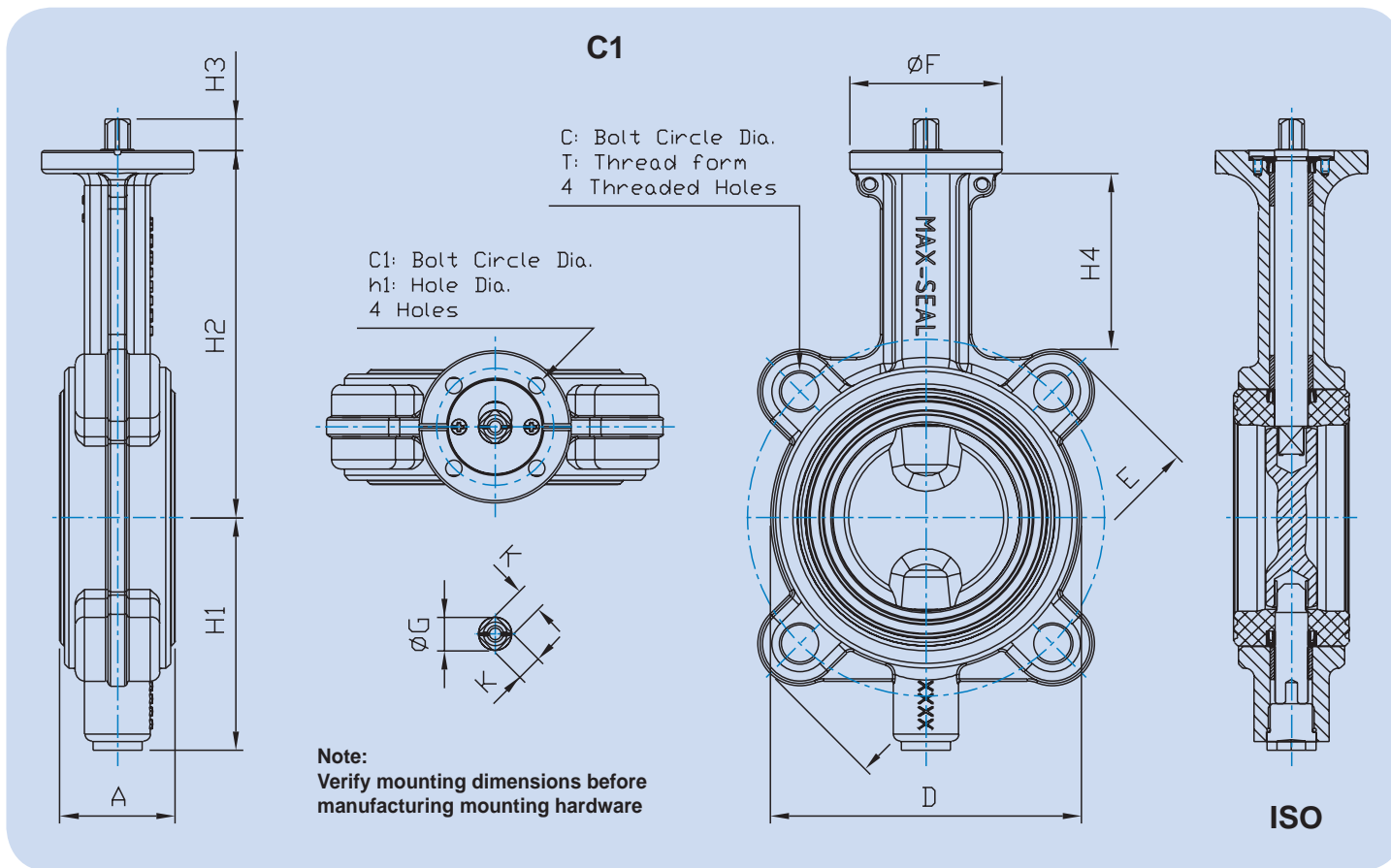

Class 150 Concentric Butterfly Valves											Flange Dimension		Mounting Base ISO 5211			Weight
SIZE	A	D	E	F	H1	H2	H3	H4	G	K	C	T	C1	H1	ISO	lb
2"	1.69	3.98	6.09	2.56	2.83	5.01	0.53	2.22	0.55	0.43	4.75	5/8-11UNC	1.97	0.28	F05	5.29
2.5"	1.81	4.50	6.84	2.56	3.23	5.53	0.53	2.27	0.55	0.43	5.50	5/8-11UNC	1.97	0.28	F05	6.90
3"	1.81	5.09	7.42	2.56	3.76	6.23	0.53	2.97	0.55	0.43	6.00	5/8-11UNC	1.97	0.28	F05	7.98
4"	2.05	6.17	8.84	3.54	4.47	6.63	0.69	2.01	0.71	0.55	7.50	5/8-11UNC	2.76	0.35	F07	11.60
5"	2.20	7.48	9.92	3.54	5.08	7.15	0.69	2.01	0.71	0.55	8.50	3/4-10UNC	2.76	0.35	F07	14.42
6"	2.20	8.35	11.23	3.54	5.59	8.05	0.73	2.22	0.87	0.67	9.50	3/4-10UNC	2.76	0.35	F07	19.18
8"	2.36	10.40	13.60	4.92	6.77	9.04	0.96	2.03	1.11	0.87	11.75	3/4-10UNC	4.02	0.43	F10	28.26
10"	2.68	12.59	16.10	4.92	8.39	10.53	0.96	2.07	1.11	0.87	14.25	7/8-9UNC	4.02	0.43	F10	39.73
12"	3.07	14.69	18.85	5.91	9.53	11.54	1.04	2.01	1/43	1.06	17.00	7/8-9UNC	4.92	0.51	F12	58.47

- Larger sizes available through 24"
- Pressure Ratings: 2"-12" 200 PSI
- Dead End Service: 2"-3" 80 psi; 4" -12" 60psi
- Vacuum Service up to 28" Hg
- Max- Seal valves are designed for bubble tight shut off either direction of flow. Each valve is factory tested 110% of their pressure rating.
- Blow out proof stem design
- A Corrosion resistant butterfly valve, designed for ANSI Class 125/150 Flanges. These valves comply with MSS- SP25, MSS-SP67 and API609 specifications, as well as meeting the requirements of MIL-V-22133C(ship)Type 1, Class A-D
- Positive Valve Position: When the handle is perpendicular to the pipe, the valve is shut. When the handle is parallel to the pipe, the valve is fully open. The orientation of the disc is indicated by a groove on the shaft end that is in line with the disc.

Max-Seal Chem-Tek Series offers longer service life, greater reliability, ease of parts replacement and interchangeability of components.

Butterfly Valve - Components / Design Features

Standard Parts List			
No.	Part Name	Qty.	Material
1	Stem	1	F316/17-4 Ph
2	Plate	1	SS
3	Screw	2	SS304
4	O-Ring	3	EPDM/VITON
5	Bushings	2	PTFE
6	Body	1	CF8M-SS316
7	Seat	1	EPDM/PTFE/VITON
8	Disc	1	CF8M-SS316
9	Bushing	1	Nylon
10	Stem Guide	1	F316/17-4 PH
11	O-Ring	1	Buna - N
12	Plug	1	F316

**Model 53
Semi-Lug Body**

Four Threaded Body Lugs, Threads can be removed if desired

**Investment Cast
Stainless Body**

Design Features

One piece body with extended neck allows clearance for flanges and up to 2 inches or more of insulation.

Primary stem seals are formed by preloaded contact between the disc and seat. A secondary seal is effected by having a stem diameter greater than the stem hole in resilient seat.

Field replaceable, phenolic bonded cartridge seat is blowout proof, stretch resistant and non-collapsible, making it an ideal seat design for high velocity or vacuum service. Our resilient seat design eliminates the need for flange gaskets.

Exploded View

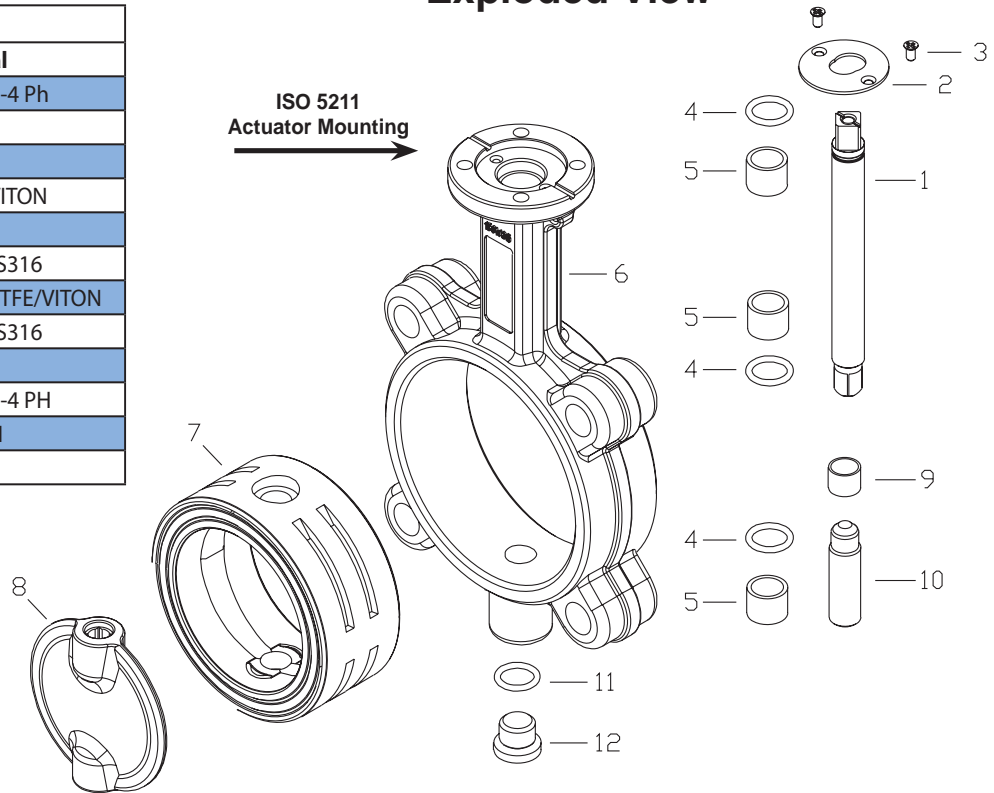

Unique 10-position Locking Handle

- Body and Disc, all sizes, are made by investment casting.
- High strength, square drive (2" - 12") ensures a positive shaft to disc connection.
- Disc floats inside the seat for positive sealing and extended seat life.
- No pins or bolts exposed to flow.

Optimal Performance Design



Accurate and smooth machined profile of disc edge requires minimal deformation of the resilient elastomer liner to achieve a positive seal. The low deformation results in low torque, less wear of the seat liner and increased operational life.

Max Seal Performance Series Butterfly Valve Model Number Codes														
Model	Body Material	Disc Material	Stem Material	Seat Material	Stem Seal O-Ring	Operator		Size						
53	Stainless Steel	SS	Stainless 316	SS	Stainless 316	SS	EPDM	E	EPDM	E	Lever	L	2"	50
	Carbon Steel	CS	Stainless 304	S4	Stainless 416	S6	Buna	B	Buna	B	Gear	G	2.5"	65
	Aluminum	AB	Alloy 20	A2	Stainless 304	S4	Viton	V	Viton	V	Bare Stem	N	3"	80
	Alloy 20	A2	Duplex	DP	Alloy 20	A2	Teflon	T			Actuator	A	4"	100
	Duplex	DP			Duplex	DP							5"	125
					17-4Ph	S7							6"	150
													8"	200
												10"	250	
												12"	300	

Ordering Example by Part Number

Semi Lug	Stainless 316	Stainless 316	Stainless 316	Buna	EPDM	Lever	Size
Model	Body Material	Disc Material	Stem Material	Seat Material	Stem Seal O-Ring	Operator	10"
53	- SS	- SS	- SS	- B	- E	- L	- 250



HANDLE AND GEAR OPERATOR DIMENSIONS

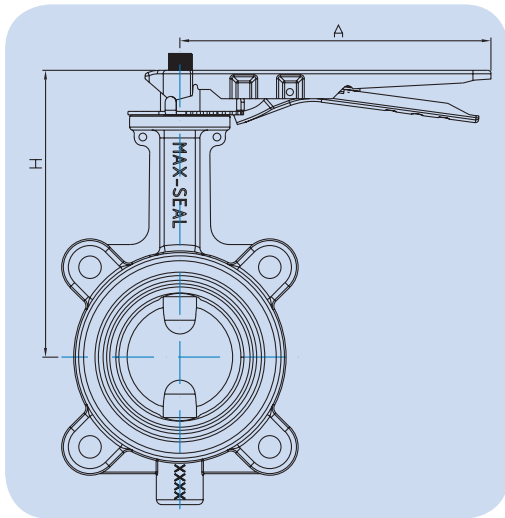

Automated Valve Consult Factory for Dimensions

All Types of Pneumatic & Electric Actuators. Consult Factory

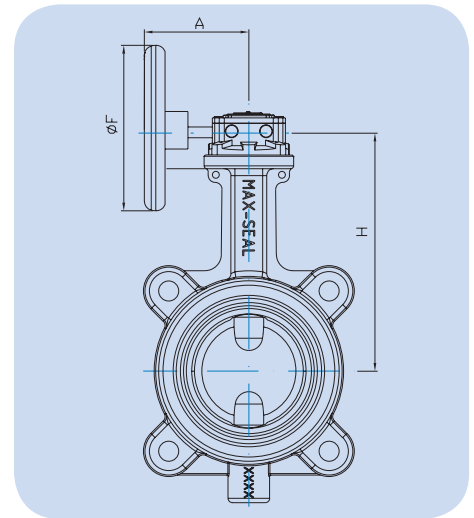

Lever-Lock 10 Position Type Handle									
Size	2"	2.5"	3"	4"	5"	6"	8"	10"	12"
H	6.49	6.81	7.71	8.22	8.74	9.64	10.89	12.38	13.39
A	8.66	8.66	8.66	10.24	10.24	10.24	14.57	14.57	-

Gear Operator									
Size	2"	2.5"	3"	4"	5"	6"	8"	10"	12"
H	5.88	6.20	7.10	7.73	8.25	9.15	10.34	11.83	12.84
F	3.94	3.94	4.72	4.72	4.72	7.87	11.81	11.81	11.81
A	4.25	4.25	4.25	4.69	4.69	4.69	8.78	8.78	8.78

Standard handles through 6" are aluminum. Other handle materials are available. Please consult factory.

VALVE FLOW COEFFICIENTS & TECHNICAL DATA

Seat Temperature Range	
Liner	Temperature
EPDM-H	5 to 250 °F
NBR-Buna-N	14 to 200 °F
Natural Rubber	- 22 to 176 °F
Hypalon	0 to 167 °F
Silicone	- 40 to 338 °F
Viton	0 to 380 °F
PTFE Silicone Backed	- 40 to 356 °F

Chem-Tek Series Torque Valve					
Size		Pressure Differential			
Inch	MM	50 psi	100 psi	200 psi	
2"	50	79	92	106	
2.5"	65	111	139	159	
3"	80	169	185	212	
4"	100	258	285	327	
5"	125	424	489	522	
6"	150	637	769	885	
8"	200	1234	1539	1770	
10"	250	1661	2155	2478	
12"	300	2251	2971	3416	

Optional Seat Materials are also Available C/F

Consult Factory for Teflon Seated Torques

Max Seal Models 53 CV Value										
Size		Angle of Opening								
Inch	MM	10°	20°	30°	40°	50°	60°	70°	80°	90°
2"	50	1.1	1.1	5.3	15	30	49	75	103	112
2.5"	65	1.1	2.1	12	28	53	81	128	180	224
3"	80	3.2	6.3	29	57	96	147	224	316	424
4"	100	5.3	15	60	113	184	275	424	624	839
5"	125	6.3	28	88	164	260	404	665	1002	1301
6"	150	7.4	54	135	235	381	601	1026	1612	2026
8"	200	23	120	241	421	671	1069	1843	3025	3659
10"	250	35	180	351	666	1019	1607	2783	4624	6042
12"	300	51	263	515	972	1487	2343	4059	6975	9272

Streamlined Disc Design Reduces Pressure Drop and Maximizes Cv

Actuator Torques

- The torque ratings in this brochure should be considered as a guide and not as an unqualified recommendation.
- Torque figures are for wet lubricated with clean non-abrasive line media.
- Temperature well within resilient seat limits
- Valve to be operated a minimum of once a day
- For applications which require clarification or additional information, consult factory.

Max-Seal Valves Are Ideally Suited for Actuated Applications

ACTUATOR MOUNTING

Max-Seal offers a broad line of automation systems for precise proportioning or on-off control in either pneumatic or electrically powered units.

Cast mounting flange accommodates all types of operators, offering ISO5211 mounting bolt circle. It is designed to accept direct actuator mounting, some sizes may require a spacer plate.

Direct mounting eliminates exposed linkages, bracket and adapter misalignment and bolt corrosion. It also provides a stronger, more compact valve package.

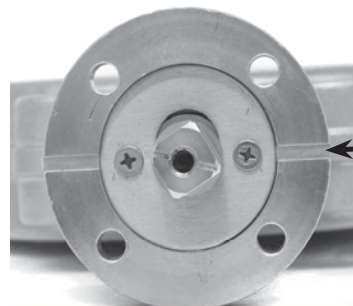

FLOW CHANNEL

Prevents Actuator Damage in Unlikely Event of Stem Leakage



Max-Seal, Inc.
4815 W. 5th Street
Lumberton, NC 28358

PO Box 1293
Lumberton, NC 28359
www.maxsealinc.com

Tel: (910) 738-2866
Fax: (910) 739-1733
email: sales@maxsealinc.com