

ACTUATORS & CONTROLS



Patent pending

EZRack Design

EZRack is a traditional rack & pinion actuator with an integrated air reservoir

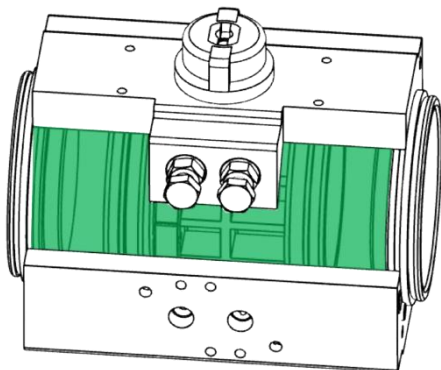

Double-acting rack and pinion

Traditional rack and pinion actuator.

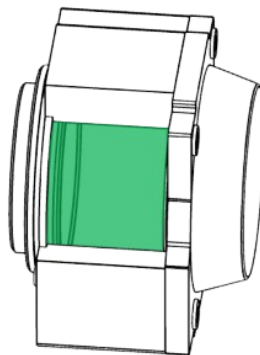
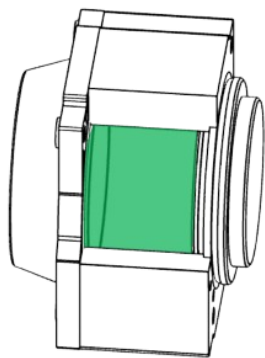

With an integral air reservoir

Air reservoirs in fail-safe systems are commonly used to replace springs in large mission-critical emergency shut-down valves.

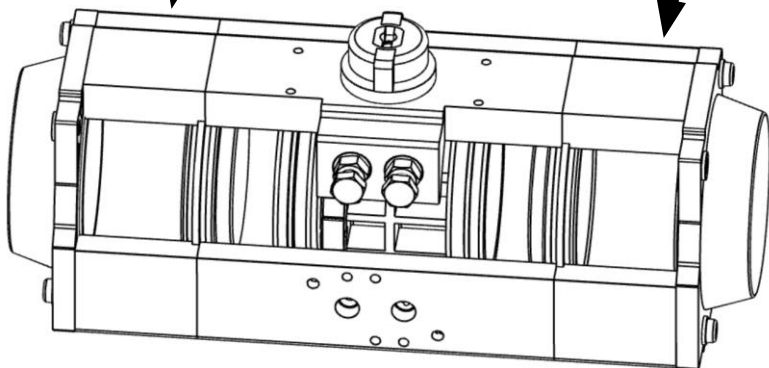

Unique features and benefits

- “0” cost and time to make the actuator double-acting, fail-close or fail-open
- “0” issues with springs
- “0” effect from environment
- 24x inventory reduction compared to traditional double-acting and spring-return actuators

Why spring-return actuators do not last in dirty environments

Dirty environments need actuators that never breathe in the environment they operate in (open-loop vs. closed-loop). Spring-returns are open-loop, whereas fail-safe air reservoirs are closed-loop. In dirty environment industries such as steel, chemical or pulp & paper, spring-return actuators vacuum in the environment, which quickly attacks and corrodes the springs, and the debris damages actuator seals.

EZRack Features and Benefits



Click QR codes on computer for link

Video



TORQUE RANGE
(In-lbs. @ 80 psi)

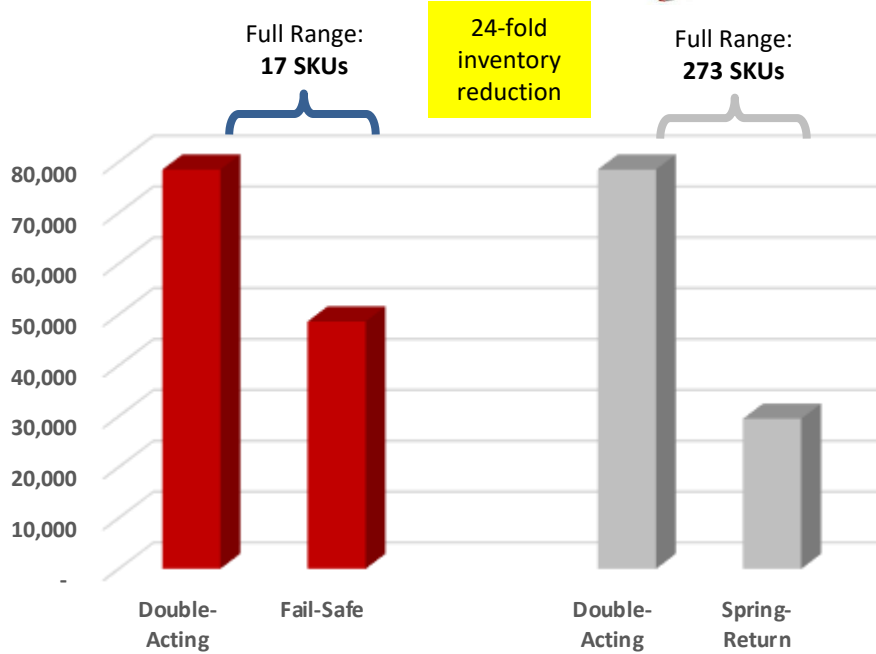

- "0" cost and time to make the actuator double-acting, fail-close or fail-open
- 24x inventory reduction

Actuator Sizes		17 models	17 models
Function	Double-Acting	Same Actuator	3 SKUs per Actuator
	Fail-Close		
	Fail-Open		
Spring Set	30 PSI, 40 PSI, 50 PSI, 60 PSI, 70 PSI, 80 PSI, 90 PSI, 100 PSI	Same Actuator	8 SKUs per Actuator

Dirty or High-Purity Environments

Video



Years of usage in dirty and caustic environment



Exterior of actuator



Clean interior

Spring-return actuators

- Always breathe in and out environment; issues in dirty or high-purity environments are inevitable; short life-span



EZRack Air Flow

Any Electrical Rating
With Tru-Flo Solenoid Valve

Double-acting

Fail-close

Fail-open

Air flow video

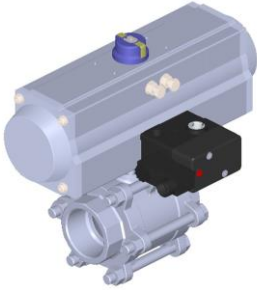

Solenoid points
LEFT



Solenoid points
RIGHT

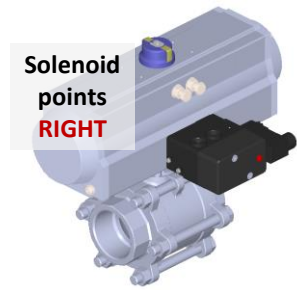

Universal Compatibility
With Any 3rd Party Solenoid

Air flow video

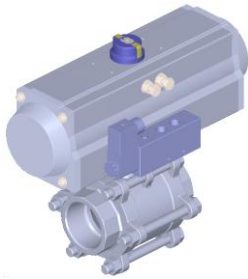

With 3rd party
5/2 DA solenoid

Pilot valve points
LEFT

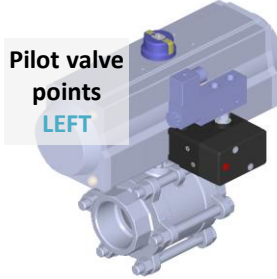

With 3rd party
3/2 DA solenoid

Pilot valve points
RIGHT

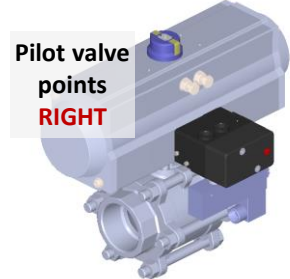

With 3rd party
3/2 DA solenoid

Universal Compatibility
With Any Positioner

Air flow video

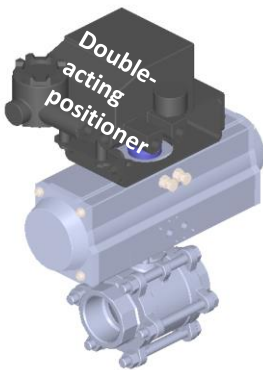

Trip valve points
LEFT

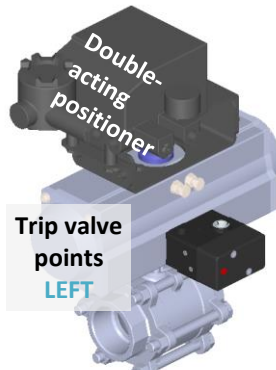

Trip valve points
RIGHT

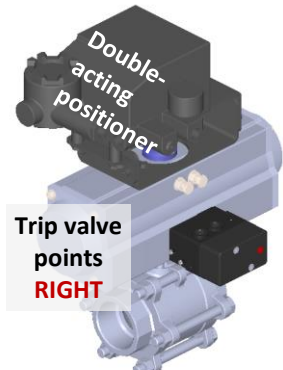

EZRack Torque Curve

Double-Acting Torque Curve

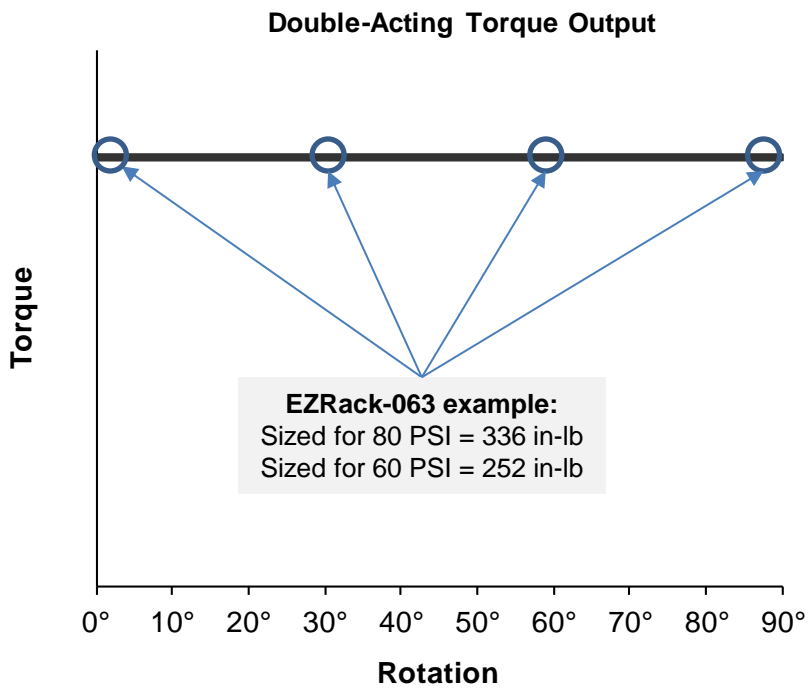

Fail-Safe Torque Curve

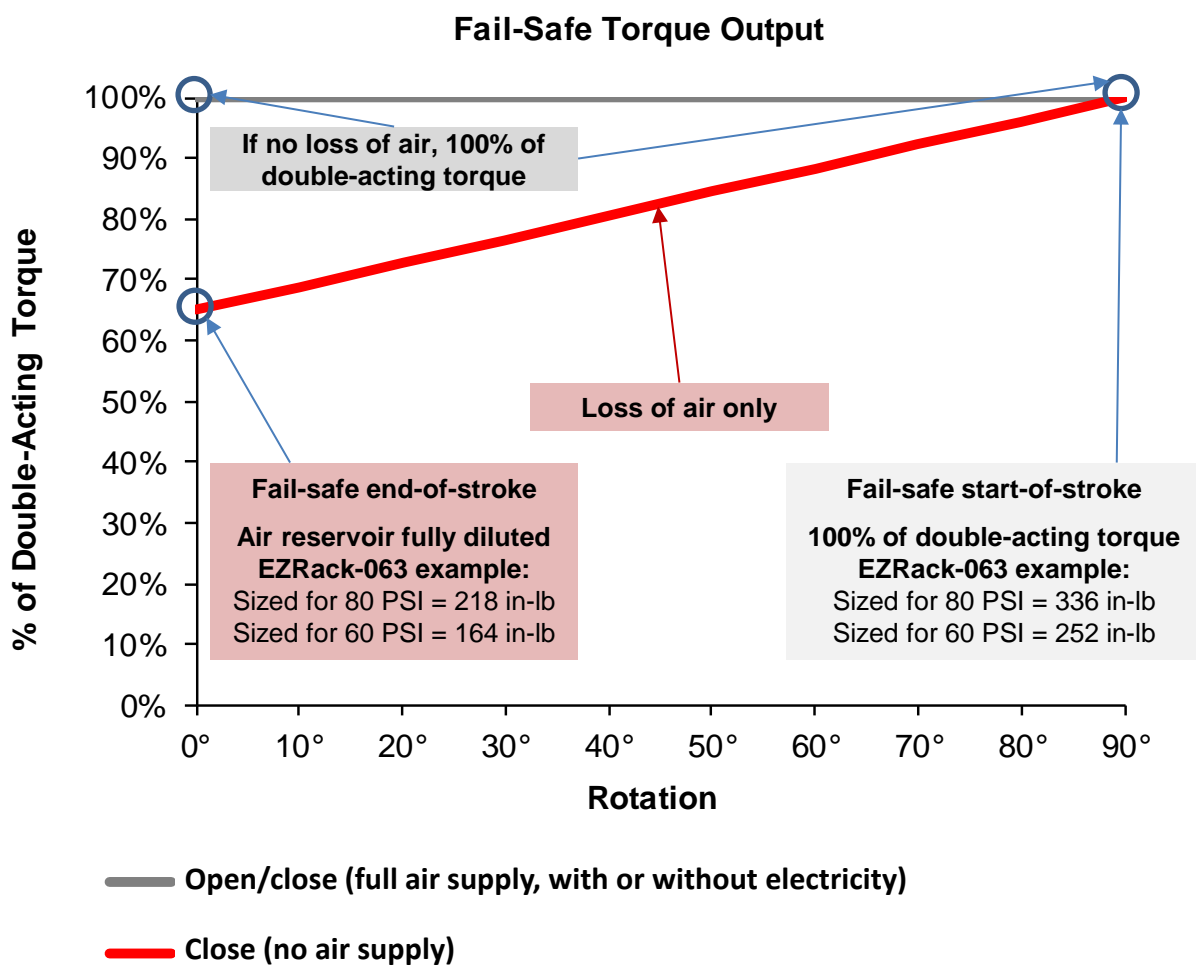

EZRack Torque Output & Weight

Metric

Double-Acting (NM)								Weight
Model / BAR	2.0	3.0	4.0	5.0	5.5	6.0	7.0	Kg
ER-32	2.7	4.1	5.9	7.4	8.1	8.8	9.8	CF
ER-52	7.7	11.6	15.5	19.3	21.3	23.2	27.1	2.1
ER-63	13.8	20.6	27.5	34.4	37.9	41.3	48.2	3.1
ER-75	22.3	33.7	44.7	55.9	61.5	67.0	78.2	4.3
ER-83	28.2	42.3	56.4	70.5	77.6	84.6	98.7	4.9
ER-92	43.2	64.8	86.5	108.0	118.8	129.6	151.2	7.3
ER-105	63.1	94.7	127.2	157.8	173.6	189.4	220.9	8.9
ER-125	108.4	162.7	216.9	271.1	298.2	325.3	379.5	13.7
ER-140	163.2	244.8	326.4	408.0	448.8	489.6	571.2	20.0
ER-160	251.4	377.0	502.7	628.4	691.3	754.1	879.7	28.5
ER-190	405.1	607.7	810.2	1,012.8	1,114.1	1,215.3	1,417.9	43.3
ER-210	557.0	835.0	1,113.0	1,392.0	1,531.0	1,670.0	1,948.0	57.3
ER-240	873.0	1,309.0	1,745.0	2,182.0	2,400.0	2,618.0	3,054.0	CF
ER-270	1,227.0	1,841.0	2,454.0	3,068.0	3,374.5	3,681.0	4,295.0	CF
ER-300	1,506.0	2,259.0	3,013.0	3,766.0	4,142.5	4,519.0	5,272.0	CF
ER-350	2,255.0	3,382.0	4,510.0	5,638.0	6,201.5	6,765.0	7,893.0	CF
ER-400	3,213.0	4,819.0	6,427.0	8,033.0	8,836.5	9,640.0	11,246.0	CF

Fail-Safe (Minimum Torque At End-Of-Stroke) (NM)								Weight
Model / BAR	2.0	3.0	4.0	5.0	5.5	6.0	7.0	Kg
ER-32	1.8	2.7	3.8	4.8	5.3	5.7	6.4	CF
ER-52	5.0	7.5	10.1	12.5	13.8	15.1	17.6	2.1
ER-63	9.0	13.4	17.9	22.4	24.6	26.8	31.3	3.1
ER-75	14.5	21.9	29.1	36.3	39.9	43.6	50.8	4.3
ER-83	18.3	27.5	36.7	45.8	50.4	55.0	64.2	4.9
ER-92	28.1	42.1	56.2	70.2	77.2	84.2	98.3	7.3
ER-105	41.0	61.6	82.7	102.6	112.8	123.1	143.6	8.9
ER-125	70.5	105.8	141.0	176.2	193.8	211.4	246.7	13.7
ER-140	106.1	159.1	212.2	265.2	291.7	318.2	371.3	20.0
ER-160	163.4	245.1	326.8	408.5	449.3	490.2	571.8	28.5
ER-190	263.3	395.0	526.6	658.3	724.1	789.9	921.6	43.3
ER-210	362.1	542.8	723.5	904.8	995.2	1,085.5	1,266.2	57.3
ER-240	567.5	850.9	1,134.3	1,418.3	1,560.0	1,701.7	1,985.1	CF
ER-270	797.6	1,196.7	1,595.1	1,994.2	2,193.4	2,392.7	2,791.8	CF
ER-300	978.9	1,468.4	1,958.5	2,447.9	2,692.6	2,937.4	3,426.8	CF
ER-350	1,465.8	2,198.3	2,931.5	3,664.7	4,031.0	4,397.3	5,130.5	CF
ER-400	2,088.5	3,132.4	4,177.6	5,221.5	5,743.7	6,266.0	7,309.9	CF

Note: Published torques are actual output torque values and do not contain safety factor.

EZRack Torque Output & Weight

Imperial

Double-Acting (In-Lb)									Weight
Model / PSI	30	40	50	60	70	80	90	100	Lbs
ER-32	25	33	44	54	63	72	81	85	CF
ER-52	70	94	118	142	165	189	212	236	4.6
ER-63	126	168	210	252	294	336	378	420	6.8
ER-75	204	274	342	409	478	545	613	682	9.5
ER-83	258	344	430	516	602	688	774	860	10.8
ER-92	395	527	659	792	923	1,054	1,186	1,318	16.1
ER-105	578	771	967	1,164	1,348	1,541	1,734	1,926	19.6
ER-125	992	1,324	1,655	1,985	2,316	2,647	2,978	3,308	30.2
ER-140	1,494	1,992	2,490	2,988	3,486	3,984	4,482	4,980	44.1
ER-160	2,301	3,067	3,834	4,601	5,369	6,136	6,903	7,669	62.8
ER-190	3,708	4,945	6,180	7,416	8,653	9,888	11,124	12,361	95.5
ER-210	5,099	6,794	8,491	10,188	11,892	13,589	15,286	16,982	126.3
ER-240	7,991	10,651	13,312	15,973	18,641	21,303	23,964	26,624	CF
ER-270	11,231	14,979	18,721	22,463	26,211	29,953	33,694	37,442	CF
ER-300	13,785	18,380	22,980	27,580	32,174	36,770	41,365	45,960	CF
ER-350	20,641	27,518	34,400	41,282	48,167	55,046	61,924	68,809	CF
ER-400	29,410	39,210	49,019	58,830	68,628	78,434	88,240	98,039	CF

Fail-Safe (Minimum Torque At End-Of-Stroke) (In-Lb)									Weight
Model / PSI	30	40	50	60	70	80	90	100	Lbs
ER-32	16	22	28	35	41	47	52	56	CF
ER-52	46	61	77	92	107	123	138	154	4.6
ER-63	82	109	136	164	191	218	246	273	6.8
ER-75	133	178	222	266	310	355	399	443	9.5
ER-83	168	224	280	336	391	447	503	559	10.8
ER-92	257	343	429	515	600	685	771	857	16.1
ER-105	375	501	629	757	876	1,002	1,127	1,252	19.6
ER-125	645	860	1,075	1,291	1,505	1,720	1,935	2,150	30.2
ER-140	971	1,295	1,618	1,942	2,266	2,589	2,913	3,237	44.1
ER-160	1,496	1,994	2,492	2,991	3,490	3,988	4,487	4,985	62.8
ER-190	2,410	3,214	4,017	4,821	5,624	6,428	7,231	8,035	95.5
ER-210	3,314	4,416	5,519	6,622	7,730	8,833	9,936	11,038	126.3
ER-240	5,194	6,923	8,653	10,382	12,117	13,847	15,577	17,305	CF
ER-270	7,300	9,737	12,169	14,601	17,037	19,469	21,901	24,338	CF
ER-300	8,960	11,947	14,937	17,927	20,913	23,900	26,887	29,874	CF
ER-350	13,417	17,886	22,360	26,834	31,309	35,780	40,250	44,726	CF
ER-400	19,117	25,486	31,863	38,239	44,608	50,982	57,356	63,725	CF

Note: Published torques are actual output torque values and do not contain safety factor.

EZRack Technical Data

Technical Specifications

Travel adjustment	Extended stopper: -5°/+5° on each side, total of 80° - 100°
Temperature range	Standard Temp: -20°C to 80°C (-4°F to 176°F)
Pressure rating	2 - 7 bar (30 - 100 psi)
Operating medium (standard)	Must use inert gases

Mounting Specifications

Actuator to valve	Mounting standard per EN ISO5211 (DIN3337 optional) and traditional mounting
Accessories	NAMUR VDI/VDE 3845

Standard and Specifications Complied

ISO 5211:2001 (E)	Industrial valves – part-turn actuator attachments
MESC SPE 77/211	Valve stem and stem adaptor dimensions and bracket drilling patterns for actuated quarter-turn valves

With adapter plate making port 2 and port 4 1/4" NPT

Namur VDI/VDE 3845	Interface between valves, actuators and auxiliary equipments
CEN/TC 69	Basic requirements for pneumatic part-turn actuators on industrial valves

EZRack Dimensions

Note: Individual model specs downloadable online

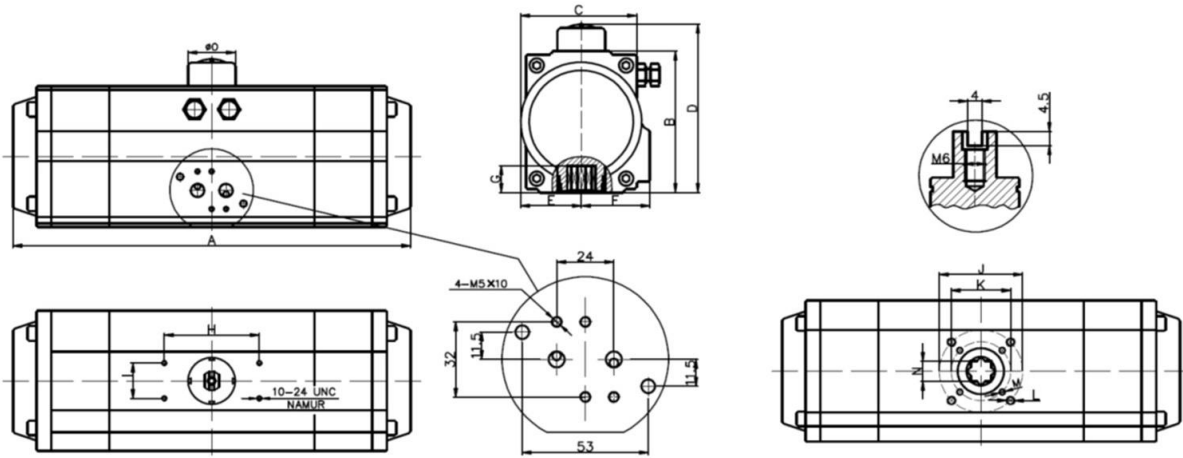

Metric	Dimensions (mm)														
Model	A	B	C	D	E	F	G	H	I	J	K	L	M	N	O
ER-032	--	--	--	--	--	--	--	--	--	--	--	--	--	--	--
ER-052	258	74	60	99	30	41	14	80	30	F05Φ50	F03Φ36	M6x11	M5x10	11	40
ER-063	290	88	69	113	36	45	18	80	30	F07Φ70	F05Φ50	M8x15	M6x12	14	40
ER-075	330	100	79	125	42	52	20	80	30	F07Φ70	F05Φ50	M8x13	M6x11	14	40
ER-083	332	109	88	134	46	53	20	80	30	F07Φ70	F05Φ50	M8x15	M6x12	17	40
ER-092	409	120	97.5	145	51	58	22	80	30	F07Φ70	F05Φ50	M8x13	M6x12	17	40
ER-105	450	133	105.5	158	57.5	64	24	80	30	F10Φ102	F07Φ70	M10x18	M8x14	22	40
ER-125	540	155	120.5	182	67.5	70	27.5	80	30	F10Φ102	F07Φ70	M10x18	M8x14	22	65
ER-140	654	172	137	198	76	77	32	80	30	F12Φ125	F10Φ102	M12x22	M10x18	27	65
ER-160	730	197	159.5	224	86.5	88	34	80	30	F12Φ125	F10Φ102	M12x22	M10x18	27	65
ER-190	830	230	186	269	103	103	40	130	30	F14Φ140	/	M16x23	/	36	78
ER-210	934	255	202	294	113	113	40	130	30	F14Φ140	/	M16x25	/	36	78
ER-240	--	--	--	--	--	--	--	--	--	--	--	--	--	--	--
ER-270	--	--	--	--	--	--	--	--	--	--	--	--	--	--	--
ER-300	--	--	--	--	--	--	--	--	--	--	--	--	--	--	--
ER-350	--	--	--	--	--	--	--	--	--	--	--	--	--	--	--
ER-400	--	--	--	--	--	--	--	--	--	--	--	--	--	--	--

Imperial	Dimensions (in)														
Model	A	B	C	D	E	F	G	H	I	J	K	L	M	N	O
ER-032	--	--	--	--	--	--	--	--	--	--	--	--	--	--	--
ER-052	10.16	2.91	2.36	3.90	1.18	1.61	0.55	3.15	1.18	F05Φ1.97	F03Φ1.42	1/4-20 UNC	10-24UNC	0.43	1.57
ER-063	11.42	3.46	2.72	4.45	1.42	1.77	0.71	3.15	1.18	F07Φ2.76	F05Φ1.97	5/16-18 UNC	1/4-20 UNC	0.55	1.57
ER-075	12.99	3.94	3.11	4.92	1.65	2.05	0.79	3.15	1.18	F07Φ2.76	F05Φ1.97	5/16-18 UNC	1/4-20 UNC	0.55	1.57
ER-083	13.07	4.29	3.46	5.28	1.81	2.07	0.79	3.15	1.18	F07Φ2.76	F05Φ1.97	5/16-18 UNC	1/4-20 UNC	0.67	1.57
ER-092	16.10	4.72	3.84	5.71	2.01	2.26	0.87	3.15	1.18	F07Φ2.76	F05Φ1.97	5/16-18 UNC	1/4-20 UNC	0.67	1.57
ER-105	17.72	5.24	4.15	6.22	2.26	2.52	0.94	3.15	1.18	F10Φ4.02	F07Φ2.76	3/8-16 UNC	5/16-18 UNC	0.87	1.57
ER-125	21.26	6.10	4.74	7.17	2.66	2.76	1.08	3.15	1.18	F10Φ4.02	F07Φ2.76	3/8-16 UNC	5/16-18 UNC	0.87	2.56
ER-140	25.75	6.75	5.39	7.80	2.99	3.03	1.26	3.15	1.18	F12Φ4.92	F10Φ4.02	1/2-13 UNC	3/8-16 UNC	1.06	2.56
ER-160	28.74	7.76	6.28	8.82	3.41	3.44	1.34	3.15	1.18	F12Φ4.92	F10Φ4.02	1/2-13 UNC	3/8-16 UNC	1.06	2.56
ER-190	32.68	9.06	7.32	10.59	4.06	4.06	1.57	5.12	1.18	F14Φ5.51	/	5/8-11 UNC	/	1.42	3.07
ER-210	36.77	10.04	7.95	11.57	4.45	4.45	1.57	5.12	1.18	F14Φ5.51	/	5/8-11 UNC	/	1.42	3.07
ER-240	--	--	--	--	--	--	--	--	--	--	--	--	--	--	--
ER-270	--	--	--	--	--	--	--	--	--	--	--	--	--	--	--
ER-300	--	--	--	--	--	--	--	--	--	--	--	--	--	--	--
ER-350	--	--	--	--	--	--	--	--	--	--	--	--	--	--	--
ER-400	--	--	--	--	--	--	--	--	--	--	--	--	--	--	--

EZRack Build of Material

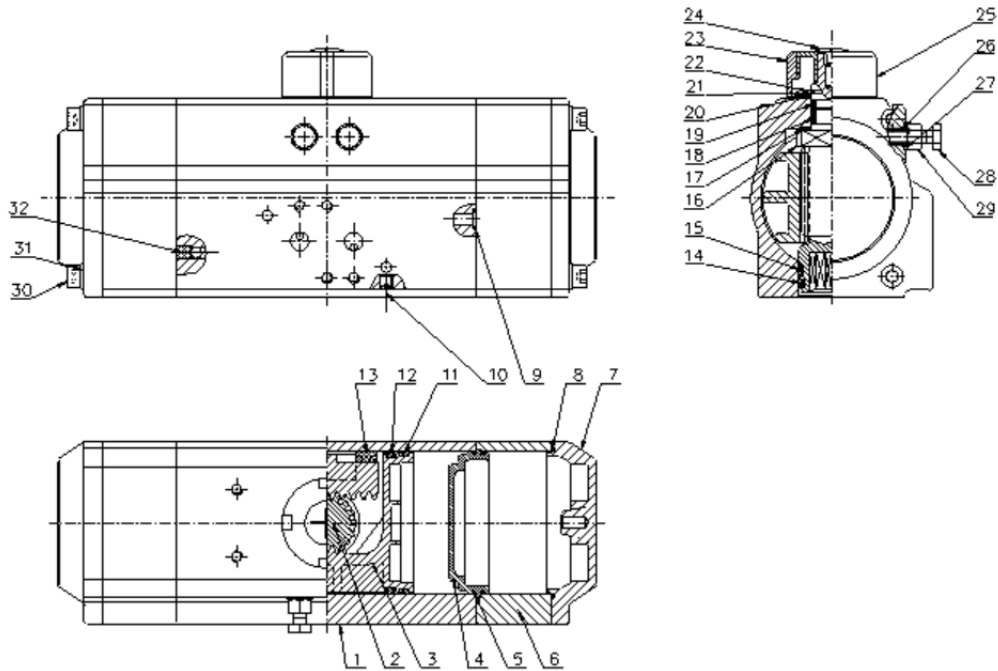

BOM

#	Description	Material	QTY	Protection
1	Body	Aluminum	1	Anodized
2	Pinion	Carbon steel	1	Nickel plated
3	Piston	Aluminum	2	Anodized
4	AR Plate	Aluminum	2	Anodized
5	O-ring	NBR	4	
6	AR Compartment	Aluminum	2	Anodized
7	Cap	Aluminum	2	Epoxy coated
8	O-ring	NBR	2	
9	O-ring	NBR	2	
10	Plug	Stainless steel	1	
11	Guide Ring	POM	2	
12	O-ring	NBR	2	
13	Support Ring	POM	2	
14	O-ring	NBR	1	
15	Bearing	POM	1	
16	Spacer	Carbon steel	1	Phosphatized / galvanized
17	Thrust Bearing	POM	1	
18	Bearing	POM	1	
19	O-ring	NBR	1	
20	Thrust Bearing	POM	1	
21	Thrust Washer	Stainless steel	1	
22	Circlip	Stainless steel	1	
23	Indicator Pointer	Plastic	4	
24	Indicator Nut	Plastic	1	
25	Indicator Pointer	Plastic	1	
26	O-ring	NBR	2	
27	Washer	Stainless steel	2	
28	Adjusting Screw	Stainless steel	2	
29	Adjusting Nut	Stainless steel	2	
30	Cylinder Screw	Stainless steel	8	
31	Washer	Stainless steel	8	
32	Rubber Plug	NBR	2	

EZRack Ordering Codes

Product Type	Model Number	Actuator Attributes		
		Thread	Corrosion Rating	Temp. Rating
ER	- X	- X	X	- X
ER	032, 052, 063, 075, 083, 092, 105, 125, 140, 160, 190, 210, 240, 270, 300, 350, 400	1: Imperial 2: Metric	1: Standard version	ST: Standard temp (-20°C to 80°C or -4°F to 176°F) HT: High temp (-20°C to 160°C or -4°F to 320°F) LT: Low temp (-40°C to 80°C or -40°F to 176°F)



ACTUATORS & CONTROLS

Headquarters

4815 West 5th St.
Lumberton, NC 28358

Tel: 910-738-8904

Fax: 910-738-9112