



## Lined Valves

# Chem-Flo Series

Lined Valves Designed for High Corrosion, High Purity

### PFA Lined Ball Valves

Full Port 150# Flanged Ends  
Ductile & Stainless Bodies  
Size Range ½"-6"

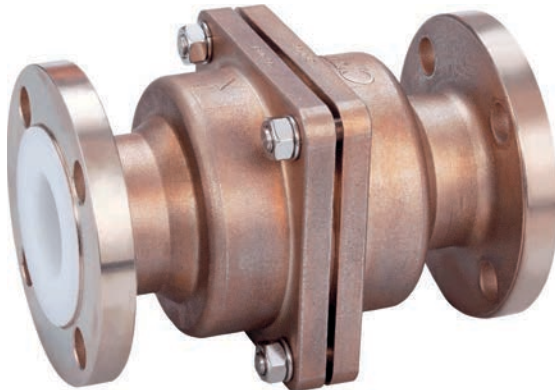

### Ball Check Valves

PFA Lined  
Full Port 150# Flanged Ends  
Ductile & Stainless Bodies  
Size Range ½"-4"

### Fully Lined Butterfly Valves

Wafer & Lug Types  
Ductile & Stainless Bodies  
Size Range: 2"-24"



**Chem-Flo Valves Replace  
High Alloy Valves**



Max-Seal, Inc.  
4815 West 5th St.  
Lumberton, NC 28358

P.O. Box 1293  
Lumberton, NC 28359  
[www.maxsealinc.com](http://www.maxsealinc.com)

910-738-2866  
910-739-1733  
[sales@maxsealinc.com](mailto:sales@maxsealinc.com)



# PTFE Lined Ball Valve

## CHEM-FLO SERIES

PFA Lined Valves Designed for High Corrosion, High Purity

Model:  
F15-DI-FAA-L

Size Range:  
1/2"-6"

Temperature Range:  
14° F ~ +320° F  
-10° C ~ +160° C

Pressure Grade:  
ANSI Class 150

Design Advantages:

- Valve Body Design: ASME B16.42 & EN12516-3
- Face-to-Face: ASME B16.10
- Maximum Operating Pressure: 250PSI
- Actuator Mounting Pad: ISO-5211
- VOC Test Verified by ISO-15848-1

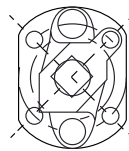

ISO 5211

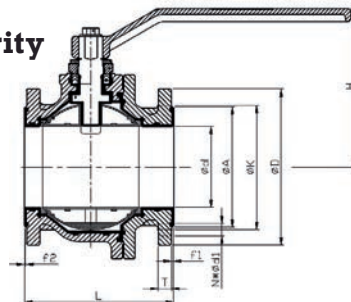

Description	Material	Qty
Body	A395 Ductile Iron+PFA	1
Cap	A395 Ductile Iron+PFA	1
Stem	ASTM A279-304+PFA	1
Ball	A351-CF8+PFA	1
Gland Packing	PTFE	1
Gland Flange	ASTM A351-CF8	1
Triangle Stopper	ASTM A276-304	1
Handle	ASTM A216-WCB	1
Seats	TFM-1600	2
C-Ring	ASTM A276-304	1
Washers	ASTM A276-304	8
Bolt	ASTM A193-Gr. B8	1
Spring Washers	ASTM A276-304	4/8
Gland Bolts	ASTM A193-Gr. B8	2
Body Stud Bolts	ASTM A193-Gr. B8	4/8
Body Nuts	ASTM A194-Gr. 8A	4/8
Spring	ASTM A313-302	1

Size	1/2"	3/4"	1"	1 1/2"	2"	2 1/2"	3"	4"	6"
CV valve	19	45	88	242	425	783	1182	2130	3000
ISO Mount	F04	F04	F05	F07	F07	F07	F07	F10	F12

Torque	0 PSI	45 PSI	90 PSI	150 PSI	200 PSI	275 PSI
1/2"	3.92	3.92	3.92	3.92	3.92	3.92
3/4"	4.9	4.9	4.9	4.9	4.9	4.9
1"	5.39	5.39	5.39	5.39	5.39	5.39
1 1/2"	8.83	8.83	8.83	8.83	8.83	8.83
2"	13.73	13.73	13.73	13.73	13.73	15.2
2 1/2"	17.65	17.65	17.65	18.14	18.14	19.1
3"	24	24	24	24	24	25.5
4"	51.98	52.96	52.96	52.96	52.96	53.9
6"	235	235	235	265	265	275

SIZE		APPROX. WEIGHT		TORQUE, IN./LBS. @ΔP=10 BAR/150PSI		FLOW RATE	
INCH	DN	LB.	KG.	OPER.	MAX PERMITTED	KVS	CV
1/2"	15	6.2	2.8	44	88	17.4	20.5
3/4"	20	12.1	5.5	88	170	61	70.5
1"	25	12.1	5.5	88	170	61	70.5
1 1/2"	40	26.4	12	176	440	188	219
2"	50	33	15	282	704	276	321
3"	80	63.8	29	660	1408	591	692
4"	100	101.2	46	1716	2819	1247	1451
6"	150	168.3	76.5	2464	4400	2755	3215

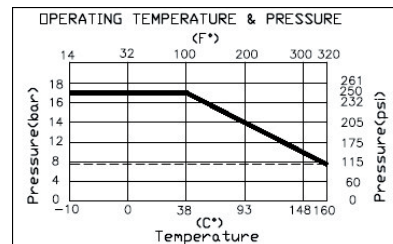

### Dimensions

Size (in)	d	H	E	L
1/2"	15	83	145	108
3/4"	20	84	145	117
1"	25	101	165	127
1-1/2"	40	128	225	165
2"	50	136	225	178
2-1/2"	65	168	350	190
3"	80	177	350	203
4"	100	233	400	229
6"	145	282	466.5	267

Unit: mm

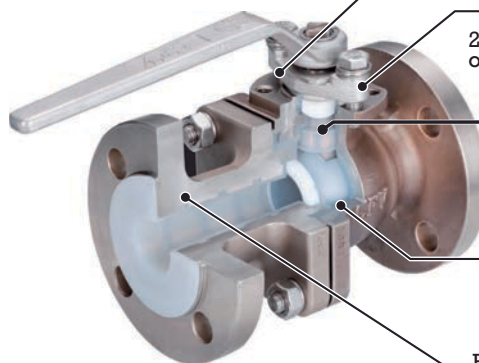

1. Semicon-class PFA liner, long life and low residue  
VOC certified to ISO 15848-1
2. Lock washer prevents the loosening of grand nut and leakage from packing
3. Anti-Blowout Stem, and low break torque
4. Double sealing body design ensures no leakage from inside or outside
5. Transfer-molding liner reduces the risks of liner detachment



# Chem-Flo Series

## PTFE Lined Butterfly Valves

See Tech Bulletin 25/26

Designed for High Corrosion and High Purity

**Models:**

- 25 - Wafer Type
- 26 - Lug Type

**Size Range:**

2" - 12"

**Materials:**

Ductile Iron Body  
Optional Stainless Steel  
and Special Alloy

**Pressure Rating:**

- 2" - 14": 150 PSI
- 16" - 24": 100 PSI

**Actuator Mounting:**

ISO - 5211 Direct Mount

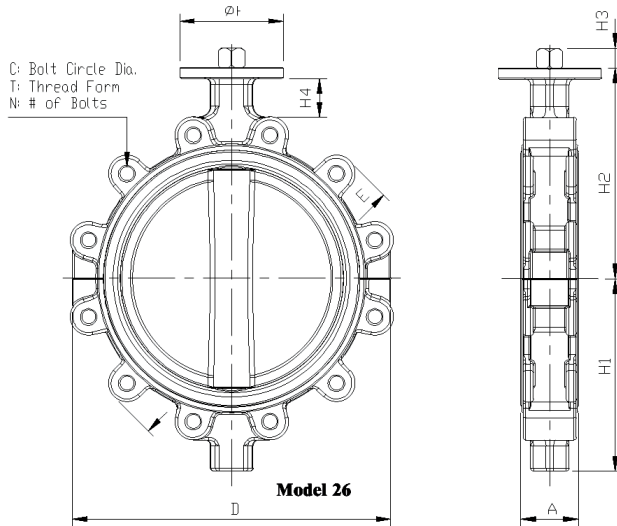

### ANSI Class 125 PTFE Lined Butterfly Valves

Size	A	Wafer [D]	Lug [D]	Wafer [H1]	Lug [H1]
2"	1.85	5.08	6.02	2.56	2.36
2.5"	1.97	5.28	6.10	2.76	2.76
3"	1.97	6.26	7.09	3.23	3.31
4"	2.19	7.76	8.07	3.78	4.02
5"	2.32	8.43	9.45	4.72	4.80
6"	2.32	10.00	10.43	5.12	5.28
8"	2.48	12.20	12.60	6.69	6.50
10"	2.87	14.57	15.16	8.66	7.64
12"	3.19	16.56	17.73	8.82	8.82

### Design Features

- 2-Piece Body Design
- Ease of Automation
- Phenolic Backed Seats
- 2 Piece Stem Design
- Epoxy Coated Body
- Low Operating Torque
- Blowout-Proof Stem
- Optional Polished Disc

### Typical Applications

- Fertilizers
- Desalination
- Bio-Technical
- Pulp and Paper
- Textile Industry
- Petro-Chemical
- Food Processing
- Semi-Conductors
- Mining and Steel
- Paint and Pigments
- Pharmaceutical Industry
- Chemical Process Industry

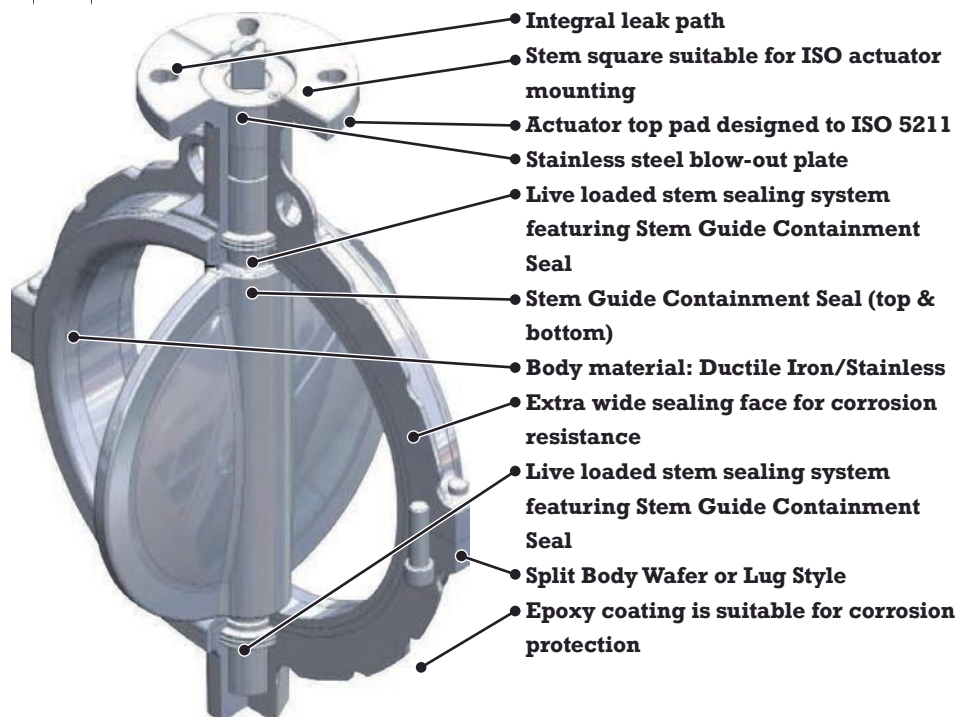



**Model:**

BCV15-SS-TT

**Size Range:**

1/2"-4"

**Temperature Range:**

-30°C~+100°C

**Pressure Grade:**

Class 150

**Optional Products (C/F)**

- PFA Lined Diaphragm Valves
- PFA Lined Plug Valves

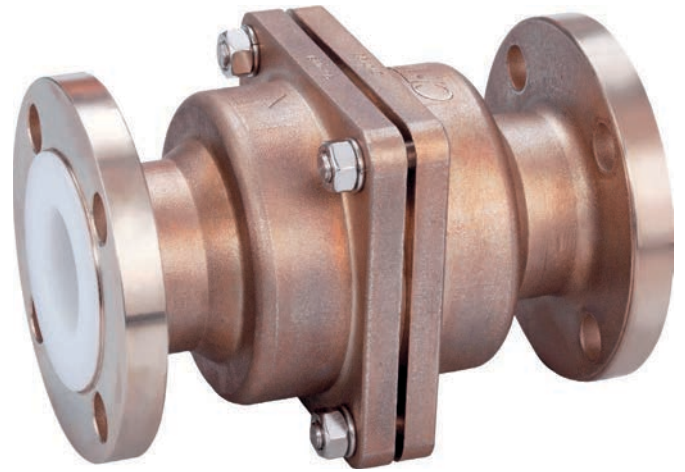

**Material List**

Item	Designation	Specification
1	Body	A351-CF8 +PFA (Fluoropolymer) Liner
2	Cap	A351-CF8 +PFA (Fluoropolymer) Liner
3	Sleeve	PTFE
4	Ball	PTFE
5	Spring	SUS304 WPA+PFA (Fluoropolymer) Liner

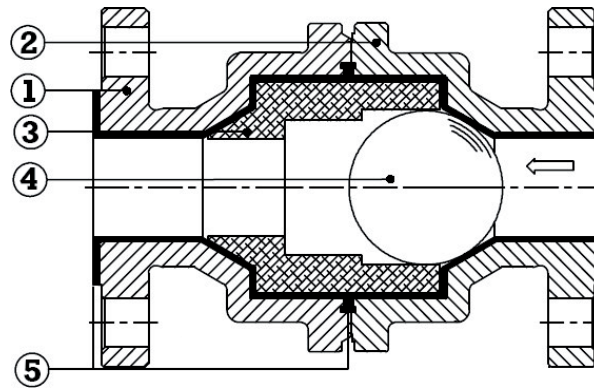

**Dimensions**

Size				JIS 10K			ANSI 150
in	DN	A	L	D	C	G	D
1/2"	15	15	130	95	70	45	89
3/4"	20	20	150	100	75	50	98
1"	25	25	160	125	90	61	108
1-1/2"	40	38.5	200	140	105	76	127
2"	50	51	230	155	120	91	152
2-1/2"	65	65	290	175	140	113	178
3"	80	76	310	185	150	123	190.5
4"	100	102	350	210	175	147	228.6

Unit: mm

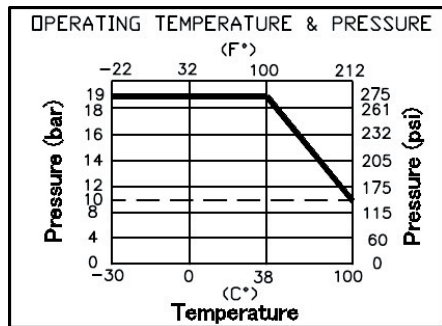
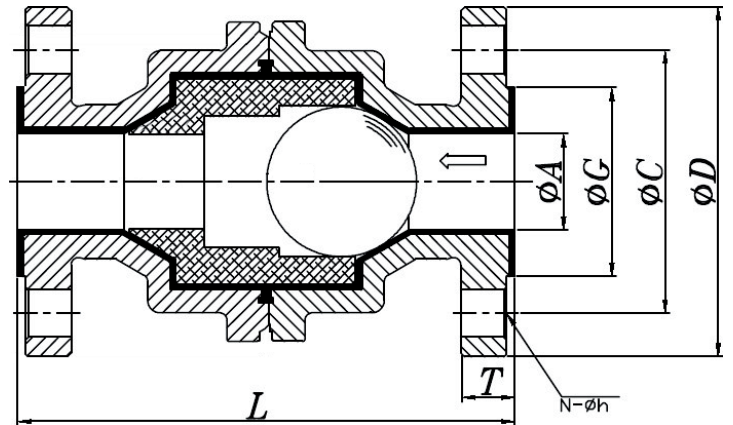

**Design Advantages**

- ASME B16.34 Valve Body Design
- ISO 5752 face-to-face
- Low Pressure Applications and no back pressure to seat
- Spring check type: Universal installation orientation
- Ball check type: Vertical installation only, with flow direction from bottom up
- Lining thickness is at least 3mm



Max-Seal, Inc.  
4815 West 5th St.  
Lumberton, NC 28358

P.O. Box 1293  
Lumberton, NC 28359  
www.maxsealinc.com

910-738-2866  
910-739-1733  
sales@maxsealinc.com