



PTFE Lined Butterfly Valves

CHEM-FLO SERIES

PTFE Lined Valves Designed for High Corrosion, High Purity

Model:

25 - Wafer Type
26 - Lug Type

Size Range:

2"-24"

Pressure Rating:

2"-14": 150 PSI
16"-24": 100 PSI

Materials:

Ductile Iron Body
Optional Stainless Steel
And Special Alloys

ISO-5211 Direct
(Actuator Mounting)



Typical Applications

- Fertilizers
- Desalination
- Bio-Technical
- Pulp and Paper
- Textile Industry
- Petro-Chemical
- Food Processing
- Semi-Conductors
- Mining and Steel
- Paint and Pigments
- Pharmaceutical Industry
- Chemical Process Industry

Design Advantages

- 2-Piece Body Design
- Epoxy Coated Body
- Ease of Automation
- Low Operating Torque
- Phenolic Backed Seats
- Blowout-proof Stem
- 2-Piece Stem Design

(910) 738-2866
(910) 739-1733

2-Piece Body - Ideal for Easy Maintenance

www.maxsealinc.com

sales@maxsealinc.com

Butterfly Valve - Components/Design Features

Standard Parts List

No	Part Name	Material	Code	Qty
1	Upper Stem	SS316 17-4PH	SS S7	1
2	Lock Plate	Stainless Steel	SS	1
3	Screws	Stainless Steel	SS	2
4	Bushings	PTFE w/ Graphite	Y	3
5	Upper Body	Ductile Iron A536 Stainless CF8M	DI SS	1
6	Disc Springs	SS316	SS	6
7	Washers	PTFE	T	2
8	Disc	Stainless + PTFE	SS	1
9	Seat	PTFE	T	1
10	Seat Backing	EPDM BUNA Silicone Viton	E N S V	1
11	Lower Stem	SS316 17-4PH	SS S7	1
12	Body Bolts	Stainless Steel	SS	2
13	Lower Body	Ductile Iron A536 Stainless CF8M	DI SS	1

Exploded View
Size 2"-24"

Model 25

Model 26

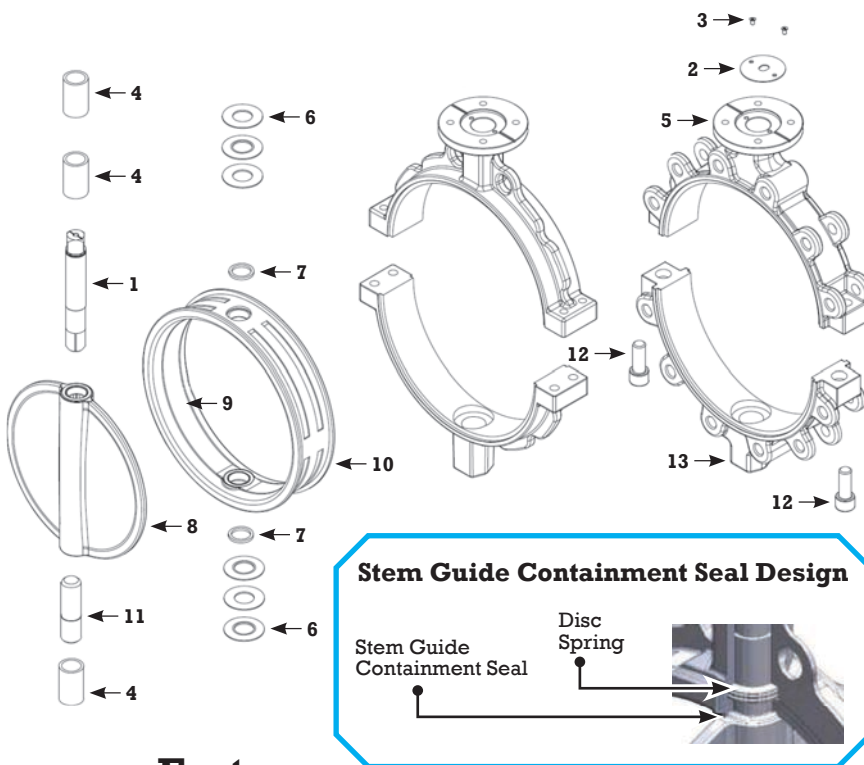

Design:

- 2"-12" stock; 14"-24" project order
- Disc options: 316SS/PTFE, Ductile Iron/ PTFE, 17-4PH/ PTFE
- Operating pressure 150 psi for 2"-14"; 100 psi for 16"-24"
- International flange compatibility
- Flange connection according to DIN 2501 PN10/16 resp.
- ANSI class 150, with standard grounding connection
- Face-to-face dimensions according to DIN-EN558-1 range 20, ISO 5752 short, BS 5155, and API 609
- Top flange according to ISO 5211, stem to EN12116
- Nearly 2" neck length meets general insulation requirements

Features:

- The Chem-Flo Series valve disc has a minimum 1/8" (3mm) thickness of pure virgin PTFE encapsulated over 316 stainless steel disc
- High strength, square drive ensures a positive shaft to disc connection
- Square drive offers direct ISO mounting of gear operator and automation equipment
- Disc floats inside the seat for positive sealing and extended seat life
- No pins or bolts exposed to flow
- A lock plate and two screws mechanically retain the shaft in the body ensuring a blowout-proof stem design

Max-Seal Performance Series Butterfly Valve Model Number Codes

Model	Body Material	Disc Material	Stem Material	Seat Material	Operator	Size	S/F						
Wafer-25 Lug-26	Ductile Iron	DI	PTFE Coated SS	TS	Stainless 316	SS	TEFLON	T	Level	L	2"	50mm	Special Feature
	Stainless 316	SS	Stainless 316	SS	17-4PH	S7	EPDM	E	Gear	G	3"	80mm	
	Alloy 20	A2	Alloy 20	A2			NBR	B	Bare Stem	N	4"	100mm	
	Duplex	DP	Duplex	DP			VITON	V	Actuator	A	6"	150mm	
											8"	200mm	
											10"	250mm	
										12"	300mm		

Performance / Design

Accurate and smooth machined profile of SS disc edge requires minimal deformation of the resilient PTFE liner to achieve a positive seal. The low deformation results in low torque, less wear of the seat liner, and increased operational life.

Max-Seal Chem-Flo Series valves are bidirectionally bubble tight.

Ordering Example by Part Number

Wafer	Ductile Iron	Stainless 316	Stainless 316	PTFE	Lever	4"
Model	Body	Disc	Stem	Seat	Operator	Size
25	DI	SS	SS	T	L	100

(910) 738-2866
(910) 739-1733

www.maxsealinc.com

sales@maxsealinc.com

Dimensions/Technical Data

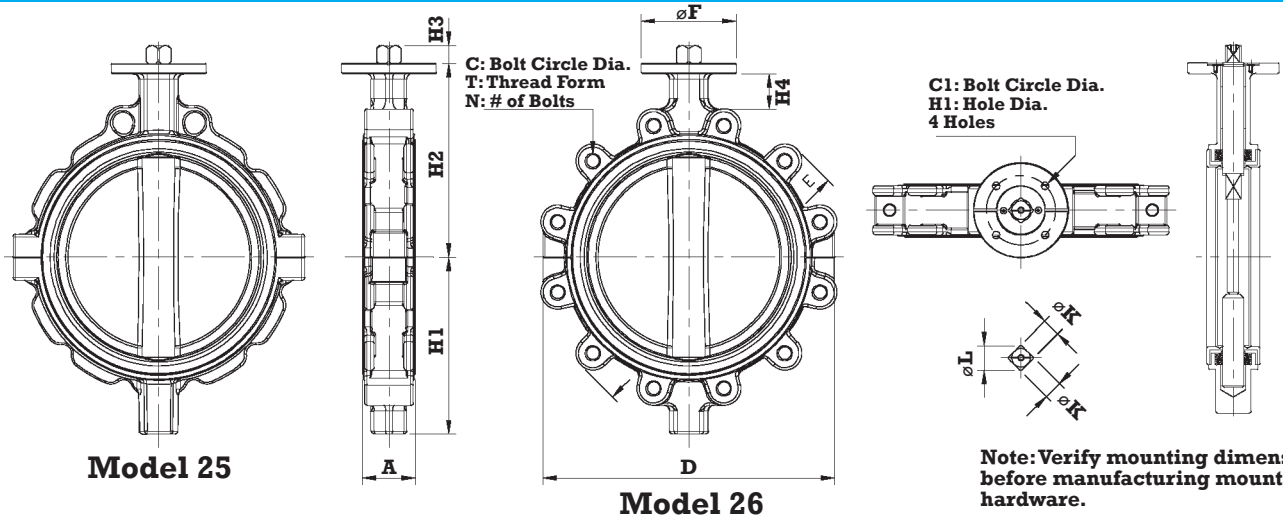

ANSI Class 125 PTFE Lined Butterfly Valves

Size	A	D		E	F	H1		H2		H3	H4	K	L	C	T	n	C1	h1	ISO	wafer	lug
		wafer	lug			wafer	lug														
2"	1.85	5.08	6.02	5.98	2.56	2.56	2.36	5.12	5.43	0.53	1.85	0.43	0.56	4.75	5/8-11unc	4	1.97	0.28	F05	5.7	8.8
2 1/2"	1.97	5.28	6.10	7.01	2.56	2.76	2.76	5.43	5.59	0.53	1.18	0.43	0.56	5.50	5/8-11unc	4	1.97	0.28	F05	7.1	10.1
3"	1.97	6.26	7.06	7.52	2.56	3.23	3.31	5.35	5.59	0.53	1.18	0.43	0.56	6.00	5/8-11unc	4	1.97	0.28	F05	8.8	11.9
4"	2.19	7.76	8.07	9.02	3.54	3.78	4.02	6.50	6.34	0.69	1.38	0.55	0.71	7.50	5/8-11unc	8	2.76	0.35	F07	14.3	15.9
5"	2.32	8.43	9.45	10.00	3.54	4.72	4.80	6.89	7.09	0.69	1.26	0.55	0.71	8.50	3/4-10unc	8	2.76	0.35	F07	15.4	19.0
6"	2.32	10.00	10.43	10.98	3.54	5.12	5.28	7.48	7.32	0.73	1.57	0.67	0.87	9.50	3/4-10unc	8	2.76	0.35	F07	21.2	25.3
8"	2.48	12.20	12.60	13.50	4.92	6.69	6.50	9.09	9.21	0.96	1.65	0.87	1.11	11.75	3/4-10unc	8	4.02	0.43	F10	32.2	50.7
10"	2.87	14.57	15.16	15.98	4.92	8.66	7.64	10.24	10.75	0.96	1.97	0.87	1.11	14.25	7/8-9unc	12	4.02	0.43	F10	46.3	70.5
12"	3.19	16.65	17.72	19.02	5.51	8.82	8.82	11.30	11.89	1.04	1.97	1.06	1.43	17.00	7/8-9unc	12	4.02	0.43	F10	67.5	88.7

Construction Features

Technical Information

- Standard bodies made of ductile iron with powder coating
- Seat made of high quality plastic PTFE with a minimum thickness of 3mm (0.12") for corrosive or abrasive services
- The steel pressure ring transfers the belleville-spring action and elastomer compression force onto liner and disc hub, providing a bubble-tight stem sealing mechanism for upper and lower stem sealing areas
- Wide, chamfered sealing surface prevents radial cold flow of liner under flange bolting forces, eliminating any need of additional gaskets
- Pressure testing according to DIN 3230 Part 3, EN 12266, API 598
- Material and test certificates according to EN 10204-3.1B
- Spark testing of disc encapsulations and liners according to DIN IEC 243T2

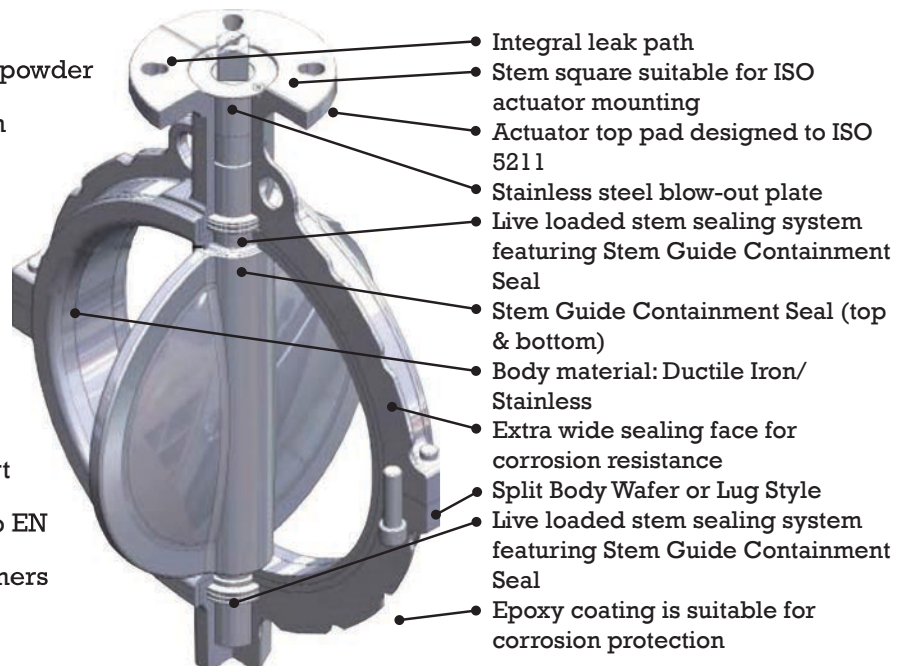

Handle and Gear Operator Dimensions

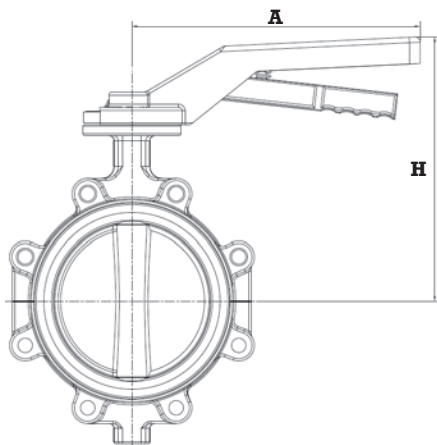

Chem-Flo Series

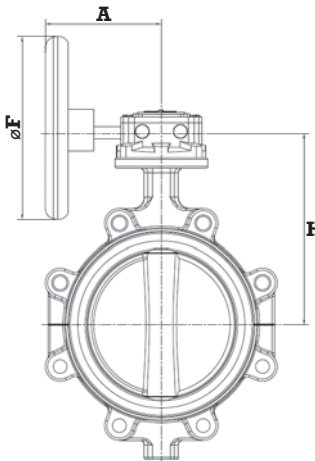

Standard Die Cast Aluminum Handles
Optional SS304 Stainless Steel Handles

Level-Lock 10 Position Type Handle

Size	2"	2.5"	3"	4"	5"	6"	8"	10"	12"
H	7.99	8.15	8.15	9.41	10.16	10.39	13.19	14.73	15.87
A	7.68	7.68	7.68	10.59	10.59	10.59	12.99	12.99	12.99

Gear Operator

Size	2"	2.5"	3"	4"	5"	6"	8"	10"	12"
H	5.43	5.59	5.59	6.34	7.09	7.32	9.21	10.75	11.89
F	4.72	4.72	4.72	7.87	7.87	7.87	11.81	11.81	11.81
A	4.25	4.25	4.25	4.69	4.69	4.69	8.78	8.78	8.78

Valve Flow Coefficients & Technical Data

Seat and Backup Temperature Range

Seat Material	Seat Backing Material	Temperature Range	
		Minimum	Maximum
PTFE	NBR	5° F	185° F
	EPDM	-4° F	248° F
	Silicone	-40° F	356° F
	VITON	5° F	356° F



Actuator Mounting

Max-Seal has designed the operator mounting top plate to ISO-5211 specifications for direct mounting of manual operators and actuators. Designed to recognize industrial standards, the square stem connection provides a secure connection with most actuators without requiring brackets.

Elastomer backings provide a resilient and uniform pressure onto sealing surface for positive shut-off. Available in Silicon, Viton, EPDM, or Standard EPDM.

Automation Equipment

Max-Seal offers a wide range of automation products including handles, gear operators, rack and pinion actuators, pneumatic cylinder, and wrench arm assemblies, electric actuators, pneumatic positioners, solenoids, proximity, and limit switches.

Max-Seal Chem-Flo Cv Values

Size		Angle of Opening								
Inch	mm	10°	20°	30°	40°	50°	60°	70°	80°	90°
2	50	1	1	6	16	34	55	83	114	125
2½	65	1	2	13	32	58	90	142	200	249
3	80	4	7	33	63	106	163	249	351	471
4	100	6	16	67	126	204	306	471	693	932
5	125	7	32	98	182	289	449	728	1113	1446
6	150	8	60	151	261	424	668	1140	1791	2251
8	200	26	133	267	468	746	1188	2048	3361	4066
10	250	39	200	390	740	1132	1786	3093	5138	6714
12	300	57	292	572	1079	1652	2604	4510	7750	10302

Chem-Flo Series Torque Values

Size		Pressure Differential			
Inch	mm	0 psi	40 psi	80 psi	145 psi
2	50	248	248	274	283
2½	65	336	345	363	354
3	80	443	460	496	504
4	100	664	690	752	788
5	125	1062	1115	1230	1292
6	150	1328	1398	1584	1682
8	200	2832	3089	3478	3735
10	250	3363	3761	4372	4726
12	300	4691	5257	6195	6717

These wet seating valve torques are figured for wet service defined as lubricated with clean non-abrasive line media.



Max-Seal, Inc.
 4815 West 5th St.
 Lumberton, NC 28358

P.O. Box 1293
 Lumberton, NC 28359
 www.maxsealinc.com

910-738-2866
 910-739-1733
 sales@maxsealinc.com