

**MAX SEAL**  
Valves & Controls

**Special Alloy - HP Butterfly Valves**

# HI-TEK SERIES

Double & Triple Offset  
Size Range: 2" - 110"  
ANSI Class 150/300  
Wafer, Lug and Flanged  
Forging and Casting Options

**The Hi-Tek Series Specializes in a wide selection of special alloys**

- Titanium
- Nickel
- Monel
- Hastelloy
- Incoloy
- Inconel
- Zirconium
- Duplex
- Super Duplex



**Automation**  
Max-Seal offers a  
broad line of  
Automation Systems  
for Precise Proportional  
On - Off control in either  
Pneumatic or Electrically  
powered units.



As a part of the Flo-Tite Group, Max-Seal's High Performance Butterfly Valves are backed by over 40 years of process valve and automation experience.

[www.maxsealinc.com](http://www.maxsealinc.com)

# BUTTERFLY VALVES Ordering Codes

## High Performance Double/Triple Offset Eccentric Valve Model Number ID Codes

Model	Pressure Class	Body		Disc		Stem		Seat		Stem Packing		Operator		Size in	Size mm
Double Wafer - BW	150	316	SS	316	SS	17-4PH	S7	RPTFE	R	Graphite	G	Lever	L	2"	50
Flanged - BF	300	WCB	CS					Metal	M	RPTFE	R	Gear	G	3"	80
Triple Wafer - BWT Flanged - BFT	600											Bare Stem	N	4"	100
												Actuator	A	6"	150
														8"	200

(Always add "T" for triple offset)

Ordering Example by Part Number

## Ordering Example

Model	Pressure Class	Body		Disc		Stem		Seat		Stem Packing		Operator		Size mm
<b>Wafer</b>	150	316	SS	316	SS	17-4PH	S7	RPTFE	R	Graphite	G	Lever	L	50
<b>BW</b>	150	SS		SS		S7		R		G		L		50



# DOUBLE OFFSET BUTTERFLY VALVES Design Features

## Design Standards:

Flanged, Wafer, or Lug design for installation between ANSI 150 or 300. API 609, ANSI/ASME B16.34, soft seated.

## Body:

One-piece wafer body style or full lug style for dead end service. Both body styles offer bidirectional sealing as standard in conformance with full ASME class 150 and class 300 rating.

## Stem: Blow Out Proof Shaft

The high-strength, 17/4 PH stainless steel one-piece stem provides maximum strength for high torque applications.

## Stem Seal:

Gland flange assembly is "live loaded" with Belleville Springs. This ensures continuous compression of packing and sealing contact at the stem and body. Rocker shaped gland bridge compensates for uneven adjustments of gland bolts.

## Disc:

Standard valve disc shall be CF8M (ASTM 351) or other special alloy. The angled sealing surface allows for quick release from seat which reduces torque and seat wear.

## Integrally Cast Travel Position Stop:

Designed to prevent over travel of disc and provides a set point when calibrating automation.

## Extended Neck:

Extended neck allows for 2" of pipeline insulation and easy access to stem packing adjustment and actuator mounting.

## Top Flange:

The top flange is drilled as per ISO 5211 to accommodate direct mounting of a wide range of actuators.

## Seat Retainer Plate:

Shall follow body material and shall conform to the latest revisions of API accommodating spiral wound gaskets to seal with no special requirements. Bolting is located outside the sealing element.

## Seat:

Valve seat shall be PTFE, RTFE or MTFE as standard offering. Seat design is free floating and pressure assisted to provide an interference and pressure assisted seal to achieve a positive seal under both low and high pressures in both directions. Fire safe and metal seats are also available.

## Bearing:

Max-Seal utilizes a Stainless Steel/Teflon bearing material for soft seated valves. This Material is superior in reducing friction and side thrust and suitable for corrosive applications

## Testing:

All valves are 100% tested per API 598 and documented. Standard testing reports and MTR's can be supplied at any time at no charge. Customized testing can also be performed based on customer's requirements.

## Bi-Directional Dead End Service:

All lug valves are suitable for dead-end service to full ASME pressure rating, bidirectionally.

## Certifications



# Double Offset Valves Construction Specifications General Highlights

No.	Main Parts
1	Body
2	Seat
3	Seat retainer
4	Screws
5	Packing washer
6	Packing
7	Gland bushing
8	Gland flange
9	Studs
10	Hex nuts
11	Key
12	Stem
13	Pins
14	Disc

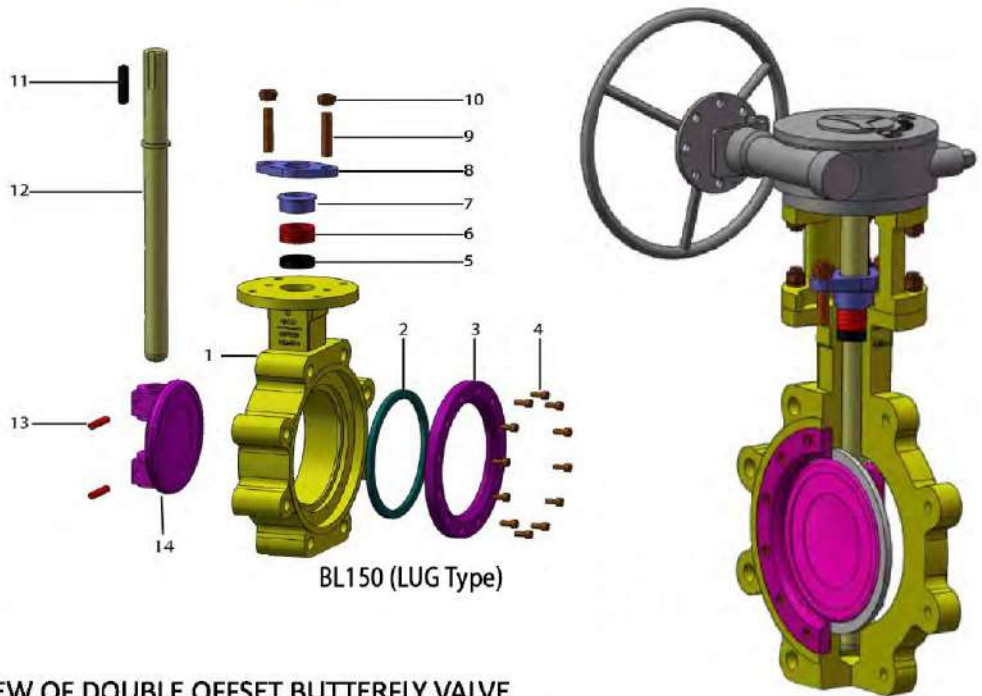

EXPLODED VIEW OF DOUBLE OFFSET BUTTERFLY VALVE

### Applicable Seat Materials

- PTFE
- RPTFE(15% Glass Filled)
- RPTFE(25% Carbon Filled)
- Viton
- TFM
- PEAK
- METAL
- Other materials can be supplied upon request

### Specifications

- Anti-static
- Blow-out proof stem
- V type packing, reliable packing seals
- Zero leakage
- Ends: Wafer, Lug, Flanged
- Uni-directional/Bi-directional sealing
- Operation: Lever, Gear, Electric, Pneumatic actuator
- Bare shaft with ISO 5211 top mounting flange (when specified)

ASME Flanged as citing	
Design	API 609
Testing	API 598
Face to face dimension	API 609
Flange ends dimension	ASME B16.5, ASME B16.47 Series A
Pressure Temperature Rating	ASME B16.34
Visual inspection of casting	MSS-SP-55

Size/Pressure produce range		Operator
Pressure Class	Wafer/Lug/ Flanged	
150LB	2" up to 110"	2"~4" Lever ; 5"~110" Gear
300LB	2" up to 60"	2"~4" Lever; 5"~60" Gear
600LB	On application	

Notes: \*Other unspecified standards and sizes are available upon request.

Notes: Above view for size below 6" valves

Size above 8" (Included 8") with additional bottom cover design, other structure same as above view.

*Due to continuous development & improvement of our Product range, we reserve the right to alter the dimensions & technical data included in this brochure.*



# DOUBLE OFFSET BUTTERFLY VALVES *Dimensions / Weights*

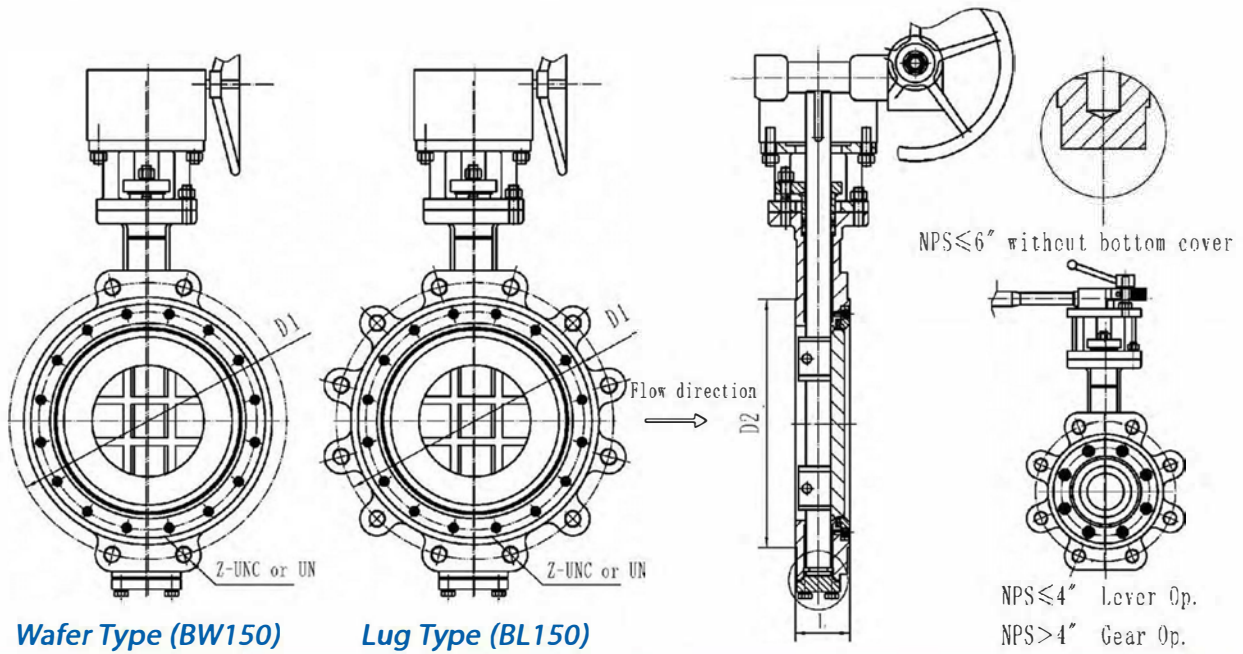

Wafer Type (BW150)

Lug Type (BL150)

Size		ASME 150LB						ASME 300LB				Weights 150LB	
(Inch)	(mm)	L	D1	D2	Z-UNC or UN	Wafer	Lug	L	D1	D2	Z-UNC or UN	Wafer	Lug
2"	50	43	120.5	92	4-UNC5/8"	10	13	43	127	92	8-UNC5/8"	16	20
2-1/2"	65	46	139.5	105	4-UNC5/8"	12	15	46	149	105	8-UNC3/4"	20	24
3"	80	48	152.5	127	4-UNC5/8"	15	24	48	168	127	8-UNC3/4"	24	31
4"	100	54	190.5	157	8-UNC5/8"	34	44	54	200	157	8-UNC3/4"	48	62
5"	125	57	216	186	8-UNC3/4"	68	53	59	235	186	8-UNC3/4"	58	77
6"	150	57	241.5	216	8-UNC3/4"	100	62	59	270	216	12-UNC3/4"	101	109
8"	200	64	298.5	270	8-UNC3/4"	147	92	73	330	270	12-UNC7/8"	132	162
10"	250	71	362	324	12-UNC7/8"			83	387.5	324	16-UN1"		
12"	300	81	432	381	12-UNC7/8"			92	451	381	16-UN1-1/8"		
14"	350	92	476	413	12-UN1"			117	514.5	413	20-UN-1-1/8"		
16"	400	102	540	470	16-UN1"			133	571.5	470	20-UN1-1/4"		
18"	450	114	578	533	16-UN1-1/8"			149	628.5	533	24-UN1-1/4"		
20"	500	127	635	584	20-UN1-1/8"			159	686	584	24-UN1-1/4"		
22"	550	127	692	641	20-UN1-1/4"			159	743	641	24-UN1-1/2"		
24"	600	154	749.5	692	20-UN1-1/4"			181	813	692	24-UN1-1/2"		
28"	700	165	863.6	800	28-UN1-1/4"			229	939.8	800	28-UN1-5/8"		
30"	750	241	914.4	857	28-UN1-1/4"			273	997	857	28-UN1-3/4"		
32"	800	241	977.9	914	28-UN1-1/2"			273	1054.1	914	28-UN1-7/8"		
36"	900	241	1085.8	1022	32-UN1-1/2"			286	1168.4	1022	32-UN2"		
40"	1000	300	1200.2	1124	36-UN1-1/2"								
42"	1050	300	1257.3	1194	36-UN1-1/2"								
48"	1200	350	1422.4	1359	44-UN1-1/2"								

Notes: \*Other sizes & pressures are available upon request.

\*If different material seats are used then torque values will change.

Due to continuous development & improvement of our Product range, we reserve the right to alter the dimensions & technical data included in this brochure.



# Triple Offset Valves Construction Specifications General Highlights

## Applicable Seat Materials

- ☐ Metal with Graphite
- ☐ Metal with PTFE
- ☐ Other materials can be supplied upon request

## Specifications

- ☐ Anti-static
- ☐ Blow-out proof stem
- ☐ Fire safe API 607
- ☐ V type packing, reliable packing seals
- ☐ Zero leakage
- ☐ Ends: Wafer, Lug, Double flange.
- ☐ Uni-directional/Bi-directional sealing
- ☐ Operation: Lever, Gear, Electric, Pneumatic actuator
- ☐ Bare shaft with ISO 5211 top mounting flange (when specified)



**Lug Type**

ASME Flanged as citing		Size/Pressure produce range		Operator
Design	API 609	Pressure Class	Wafer/Lug/ Flanged	
Testing	API 598	150LB	3" up to 80"	3"~4" Lever ; 5"~80" Gear
Face to face dimension	API 609	300LB	3" up to 40"	
Flange ends dimension	ASME B16.5 ASME B16.47 Series A	600LB	On application	
Pressure Temperature Rating	ASME B16.34			
Visual inspection of casting	MSS-SP-55			

No.	Main Parts		
1	Body	8	Gland flange
2	Laminated seat	9	Studs
3	Seat retainer	10	Hex nuts
4	Screws	11	Key
5	Packing washer	12	Stem
6	Packing	13	Pins
7	Gland bushing	14	Disc

**All Wafer Type Valves have four tapped lugs for exact & easy installation**

Notes:  
\*Other unspecified standards and sizes are available upon request.

Due to continuous development & improvement of our Product range, we reserve the right to alter the dimensions & technical data included in this brochure.

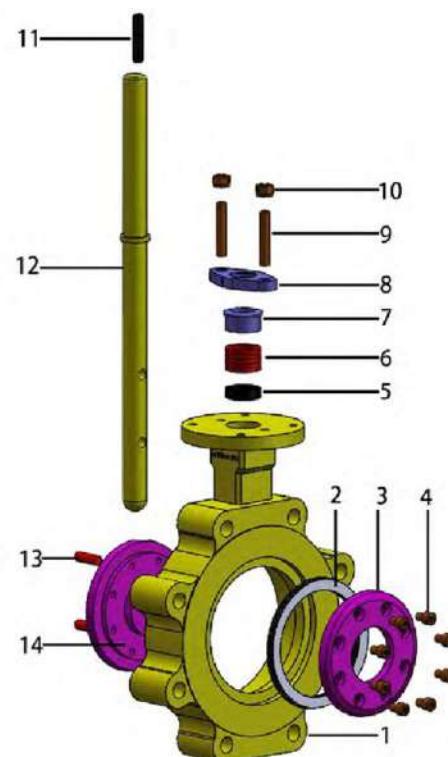



### Triple eccentric

designed valves have a metal seat which ensures a strong conical sealing principle. The centerline of the cone is rotated away from the valve centerline resulting in an ellipsoidal profile and providing the third offset. There are three offsets to the design; the center of rotation is offset from the tightness surface to allow for a total contact around the complete seal, the center of rotation of the disc is offset from the pipe centerline to allow a seal opening valve, and the seal cone tilting cancels jamming and friction. This allows for complete tightness without seal deformation and the seat-seal interface is completely eliminated ensuring long-sealing life. The design is durable even under extreme temperature fluctuations and pressures drops.

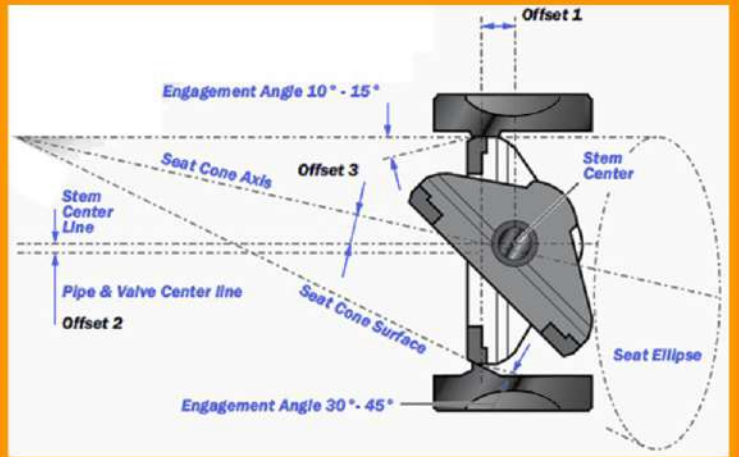

## Design Features

The triple offset butterfly valve has been designed to answer the industries demand for an alternate solution to gate valves and ball valves where weight, space, performance and the ability to modulate flow.

Lower weight vs Gate or Globe valve

Zero leakage shut off to API 598

Easy to automate

Ideal for modulating for process control

## Body Design

Body is single - piece cast construction, with options of wafer, lug, double flanged, or buttweld ends. Face to face dimensions are available for most international standards.

## Stem

One-Piece shaft ensures high pressure containment safety and maximum torque seating integrity

## Seat Seal Ring Retainer

The seal ring is clamped rigidly on the disc face by the seal ring retainer. The retainer is made of identical metal as the disc, seal ring and retainer making this a robust, composite unit for bubble tight, bi-directional sealing.



FIG. 1

**\*Fire Safe Design**

The fire test is conducted according to API 607 Section 5.

## Stem Packing

Graphite packing as standard with alternative packing materials and configurations available upon request including live loaded packing. Fugitive Emissions qualified designs are available.

# Valve Flow Coefficients & Technical Data General Highlights

## 150LB

SIZE		Cv Value										
mm	in	10°	20°	30°	40°	45°	50°	60°	70°	80°	85°	90°
50	2	0	8	22	36	44	51	60	69	72	70	70
65	2.5	2	16	38	61	71	83	109	135	146	152	150
80	3	6	33	62	94	108	118	143	176	208	230	227
100	4	16	58	106	155	178	213	274	349	433	465	473
125	5	20	94	167	230	263	310	391	488	561	604	605
150	6	40	147	242	335	382	422	560	729	925	975	1010
200	8	66	237	368	509	606	712	985	1296	1640	1715	2004
250	10	139	390	595	807	963	1168	1606	2134	2814	3180	3199
300	12	204	548	820	1138	1357	1591	2219	3067	4085	4484	4672
350	14	264	674	972	1386	1658	1994	2840	3925	5164	5828	5947
400	16	384	864	1196	1765	2155	2611	3755	5105	6975	7920	8182
450	18	508	1092	1551	2341	2881	3522	5125	7134	9511	10599	11548
500	20	626	1294	1792	2651	3304	4082	5919	8256	11429	13126	13813
600	24	1047	2251	3178	4563	5543	6568	9277	12932	17093	18328	19021

## 300LB

SIZE		Cv Value										
mm	in	10°	20°	30°	40°	45°	50°	60°	70°	80°	85°	90°
80	3	6	33	62	94	108	118	143	176	208	230	227
100	4	16	58	106	155	178	213	274	349	433	465	473
125	5	20	94	167	230	263	310	391	488	561	604	605
150	6	37	137	225	312	355	393	521	678	860	907	939
200	8	62	220	343	473	563	662	916	1206	1525	1595	1864
250	10	129	362	554	750	896	1087	1493	1985	2617	2957	2975
300	12	190	510	762	1059	1262	1480	2064	2852	3799	4170	4345
350	14	246	627	904	1289	1542	1854	2641	3650	4803	5420	5531
400	16	357	803	1112	1642	2004	2428	3492	4748	6487	7365	7609
450	18	473	1015	1442	2177	2679	3275	4766	6634	8845	9857	10739
500	20	583	1204	1667	2466	3073	3797	5504	7678	10629	12207	12846
600	24	974	2093	2956	4244	5155	6108	8627	12027	15897	17045	17689

## Standard Specifications

- Applicable Flange Standard: ANSI B16.5
- Face to Face Dimensions: API 609, MSS SP68, ISO5752
  - Actuator Mounting Flange: ISO 5211
    - Valve Design: MSS SP-68
    - Valve Design: API 609
    - Valve Marking: MSS SP-25
- Valve Testing: API 598 Inspection and Testing
- Valve Testing: MSS SP-61 Testing of Steel Valves
  - Valve Design: ANSI B16.34
- Valve to have Official API Monogram
  - Valve to API ISO 9001:2000
  - Valve to ISO/TS 29001

## Dead-End Service

MAX-SEAL lug bodies for dead-end service are offered as standard in full ANSI Class 150 and 300.

## Flow Data Rated Cv:

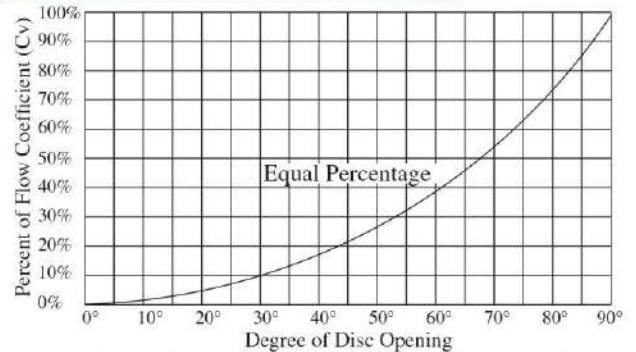

The volume of water in the United States gallons per minute that will pass through a given valve opening with a pressure drop of 1 pound per square inch. (water at temp = 60 deg.f)

## Pressure Temperature Rating:

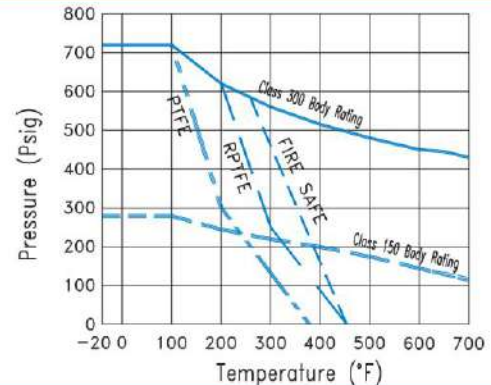

## Every Valve is Strength Tested

Shell tested to 150% of rated pressure with the disc open... hydrostatic seat tested for bi-directional positive shutoff without leakage at 110% of rated pressure. We also test for absence of leakage into valve shaft bearing areas. Only valves meeting a positive shut-off standard are approved for shipment.

## Vacuum Service

The drop-tight sealing capabilities of MAX-SEAL valves are excellent for vacuum service. Soft seated standard valves are suitable for vacuum service to 20 microns. Denote vacuum service on the order.



# TRIPLE OFFSET BUTTERFLY VALVES *Dimensions / Weights*

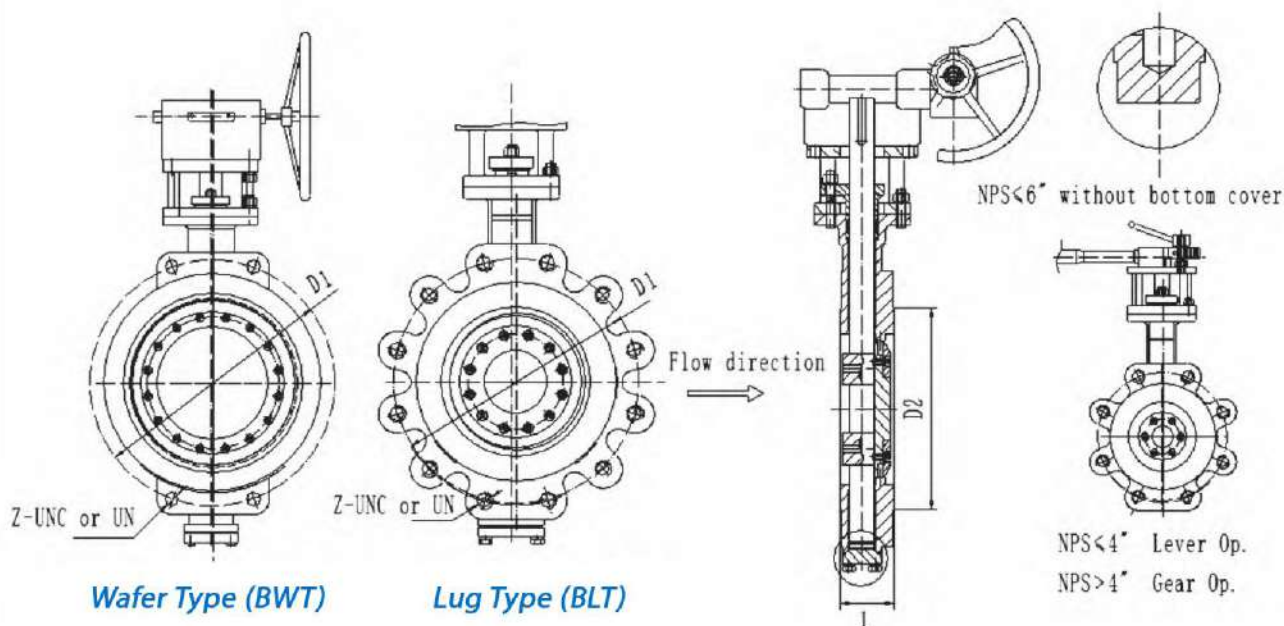

**Wafer Type (BWT)**

**Lug Type (BLT)**

Size		ASME 150LB				Weights 150LB		ASME 300LB				Weights 300LB	
(Inch)	(mm)	L	D1	D2	Z-UNC or UN	Wafer / Lug		L	D1	D2	Z-UNC or UN	Wafer / Lug	
3"	80	48	152.5	127	4-UNC5/8"	18	24	48	168	127	8-UNC3/4"	26	30
4"	100	54	190.5	157	8-UNC5/8"	26	30	54	200	157	8-UNC3/4"	35	45
5"	125	57	216	186	8-UNC3/4"	46	52	59	235	186	8-UNC3/4"	66	81
6"	150	57	241.5	216	8-UNC3/4"	57	70	59	270	216	12-UNC3/4"	84	100
8"	200	64	298.5	270	8-UNC3/4"	68	84	73	330	270	12-UNC7/8"	106	122
10"	250	71	362	324	12-UNC7/8"	100	122	83	387.5	324	16-UN1"	139	189
12"	300	81	432	381	12-UNC7/8"	147	191	92	451	381	16-UN1-1/8"	242	298
14"	350	92	476	413	12-UN1"			117	514.5	413	20-UN-1-1/8"		
16"	400	102	540	470	16-UN1"			133	571.5	470	20-UN1-1/4"		
18"	450	114	578	533	16-UN1-1/8"			149	628.5	533	24-UN1-1/4"		
20"	500	127	635	584	20-UN1-1/8"			159	686	584	24-UN1-1/4"		
24"	600	154	749.5	692	20-UN1-1/4"			181	813	692	24-UN1-1/2"		
28"	700	165	863.6	800	28-UN1-1/4"			229	939.8	800	28-UN1-5/8"		
30"	750	190	914.4	857	28-UN1-1/4"			273	997	857	28-UN1-3/4"		
32"	800	203	977.9	914	28-UN1-1/2"			273	1054.1	914	28-UN1-7/8"		
36"	900	203	1085.8	1022	32-UN1-1/2"			286	1168.4	1022	32-UN2"		
40"	1000	229	1200.2	1124	36-UN1-1/2"								
42"	1050	246	1257.3	1194	36-UN1-1/2"								
48"	1200	276	1422.4	1359	44-UN1-1/2"								

Notes: \*Other sizes & pressures are available upon request.

\*If different material seats are used then torque values will change.

\* CF-Consult Factory for Larger Sizes.

Due to continuous development & improvement of our Product range, we reserve the right to alter the dimensions & technical data included in this brochure.



# TRIPLE OFFSET BUTTERFLY VALVES *Dimensions / Weights*

## BFT150 Flanged Ends

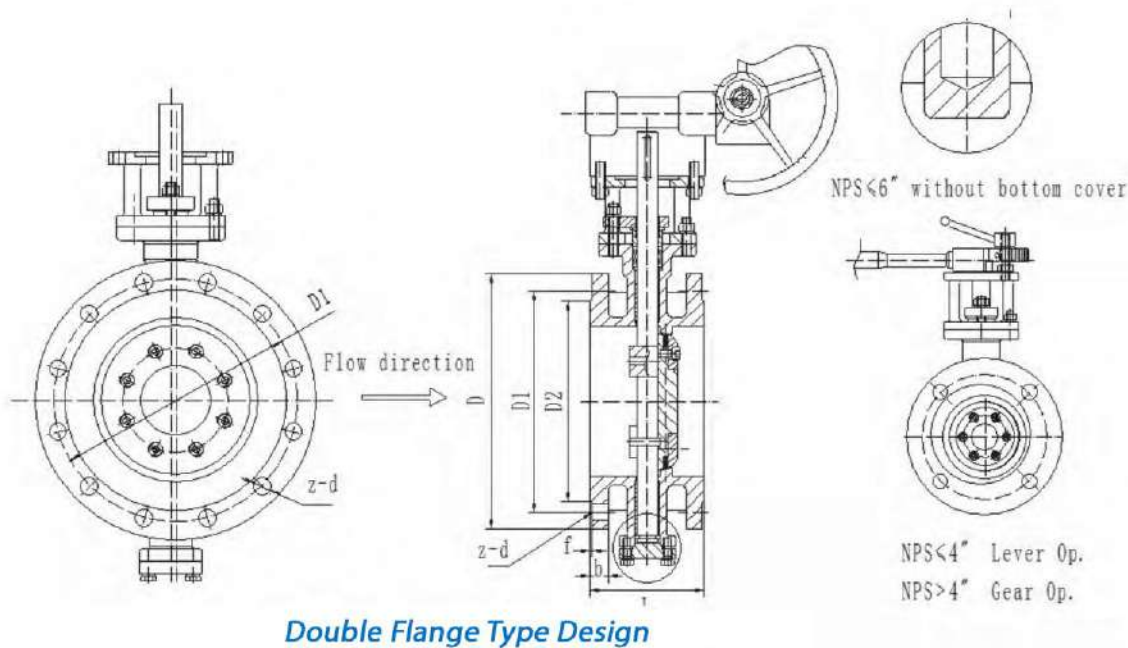

Size		ASME 150LB							Weights 150LB
(inch)	(mm)	L	D	D1	D2	b	f	z-d	Flanged
3"	80	114	190	152.5	127	19	1.6	4-19	
4"	100	127	229	190.5	157	24	1.6	8-19	
5"	125	140	254	216	186	24	1.6	8-22	
6"	150	140	279	241.5	216	26	1.6	8-22	
8"	200	152	343	298.5	270	29	1.6	8-22	
10"	250	165	406	362	324	31	1.6	12-25	
12"	300	178	483	432	381	32	1.6	12-25	
14"	350	190	533	476	413	35	1.6	12-29	
16"	400	216	597	540	470	37	1.6	16-29	
18"	450	222	635	578	533	40	1.6	16-32	
20"	500	229	698	635	584	43	1.6	20-32	
24"	600	267	813	749.5	692	48	1.6	20-35	
28"	700	292	835	795.3	762	45	2	40-22	
30"	750	318	885	846.1	813	45	2	44-22	
32"	800	318	940	900.1	864	46.6	2	48-22	
36"	900	330	1055	1009.6	972	52.9	2	44-26	
38"	950	410	1125	1070	1022	54.5	2	40-30	
40"	1000	410	1175	1120.8	1080	56.1	2	44-30	
42"	1050	410	1225	1171.6	1130	59.3	2	48-30	
48"	1200	470	1390	1335.1	1280	65.6	2	44-33	

Notes: \*Other sizes & pressures are available upon request.

\* CF-Consult Factory for Larger Sizes.

Due to continuous development & improvement of our Product range, we reserve the right to alter the dimensions & technical data included in this brochure.



# TRIPLE OFFSET BUTTERFLY VALVES *Dimensions / Weights*

## BFT300 Flanged Ends

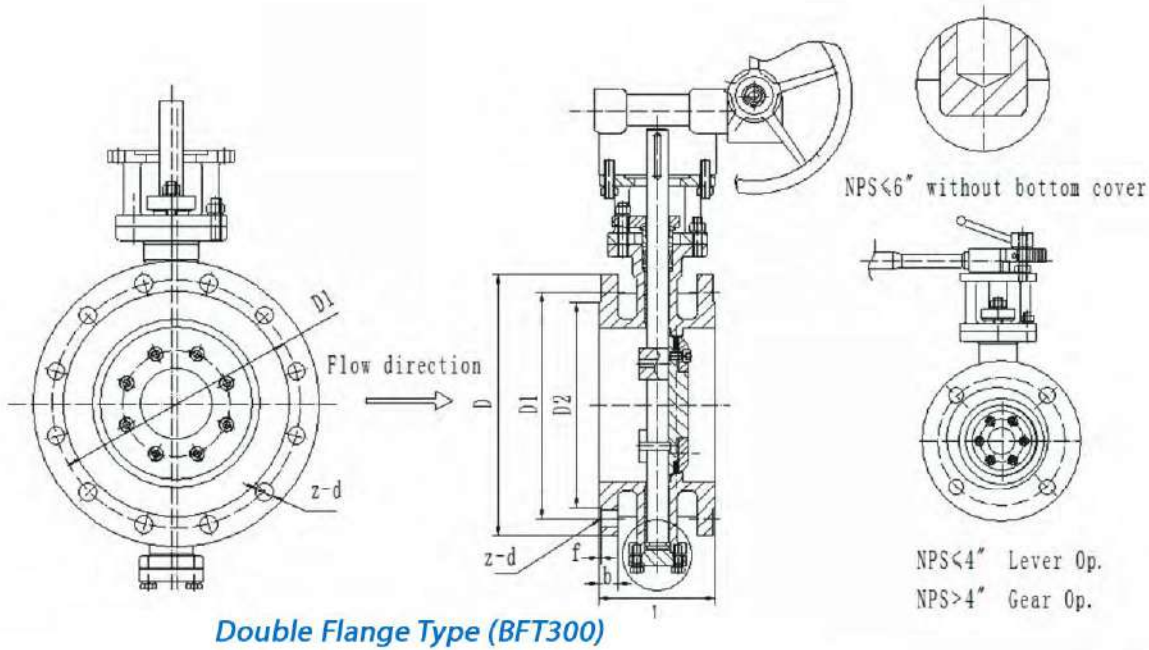

Size		ASME 300LB							Weights 300LB
(Inch)	(mm)	L	D	D1	D2	b	f	z-d	Flanged
3"	80	180	210	168	127	29	1.6	8-22	
4"	100	190	254	200	157	32	1.6	8-22	
5"	125	200	279	235	186	35	1.6	8-22	
6"	150	210	318	270	216	37	1.6	12-22	
8"	200	230	381	330	270	41	1.6	12-25	
10"	250	250	444	387.5	324	48	1.6	16-29	
12"	300	270	521	451	381	51	1.6	16-32	
14"	350	290	584	514.5	413	54	1.6	20-32	
16"	400	310	648	571.5	470	57	1.6	20-35	
18"	450	330	711	628.5	533	60	1.6	24-35	
20"	500	350	775	686	584	64	1.6	24-35	
24"	600	390	914	813	692	70	1.6	24-41	
28"	700	430	920	857.2	787	89.4	2	36-36	
30"	750	450	990	920.8	845	94.1	2	36-39	
32"	800	470	1055	977.9	902	103.6	2	32-42	
36"	900	510	1170	1089	1010	103.6	2	32-45	
38"	950	530	1220	1139.8	1060	111.6	2	36-45	
40"	1000	550	1275	1190.6	1114	116.3	2	40-45	
42"	1050	570	1335	1244.6	1168	119.5	2	36-48	
48"	1200	630	1510	1415	1327	129	2	40-51	

Notes: \*Other sizes & pressures are available upon request.

\* CF-Consult Factory for Larger Sizes.

Due to continuous development & improvement of our Product range, we reserve the right to alter the dimensions & technical data included in this brochure.



# BUTTERFLY VALVES Torque & Top Flange

## Actuator Mounting Information Double Offset Design

Size		ASME 150LB				ASME 300LB			
(Inch)	(mm)	Torque		Top flange	Shaft ends	Torque		Top flange	Shaft ends STEM
		N.M	in-lb	ISO 5211	□K / d	N.M	in-lb	ISO 5211	□K / d
2"	50	30	265	F07	11mm	50	442	F07	11mm
2-1/2"	65	34	300	F07	14mm	76	672	F07	14mm
3"	80	37	327	F07	14mm	78	690	F07	14mm
4"	100	52	460	F07	14mm	113	1000	F07	17mm
5"	125	118	1044	F10	17mm	289	2557	F10	17mm
6"	150	136	1202	F10	17mm	339	3000	F10	22mm
8"	200	210	1860	F12	22mm	599	5301	F12	27mm
10"	250	464	4107	F12	22mm	1130	10000	F12	27mm
12"	300	600	5310	F14	27mm	1695	15000	F14	34mm
14"	350	980	8674	F14	27mm	2486	22000	F14	36mm
16"	400	1330	11771	F16	34mm	4294	38000	F16	40mm
18"	450	2486	22002	F16	40mm	5085	45000	F16	46mm
20"	500	3925	34740	F25	46mm	6893	61000	F25	50mm
24"	600	4700	41600	F25	φ 70	10735	Consult	F30	φ 90

Notes: \*Other sizes & pressures are available upon request.

\*Torque value excluded safety factor for reference.

\*Up to 20", shaft ends in square type, 24" and above valves' shaft in round type.

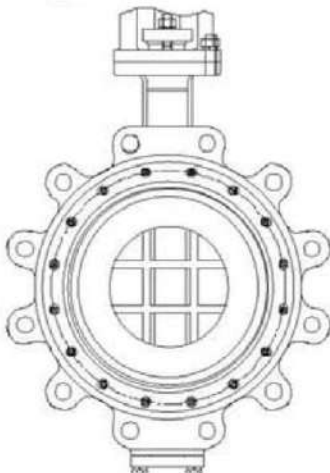

**MODEL:**  
**BL150/BL300**  
**BW150/BW300**  
Bare shaft

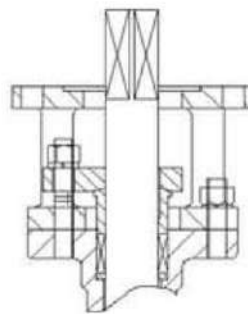

Double offset butterfly valve

\* CF-Consult Factory for Larger Sizes.

Top flange (ISO 5211)

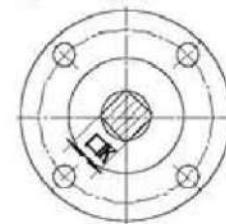

Square type

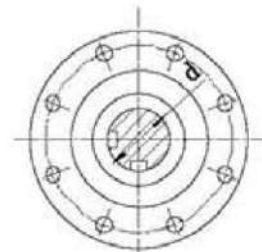

Round type

Due to continuous development & improvement of our Product range, we reserve the right to alter the dimensions & technical data included in this brochure.



# Actuator Mounting Information

## Triple Offset Design

Size		ASME 150LB				ASME 300LB			
(Inch)	(mm)	Torque		Top flange	Shaft ends	Torque		Top flange	Shaft ends
		N.M	in-lb	ISO 5211	□K / d	N.M	in-lb	ISO 5211	□K / d
3"	80	150	1328	F07	14mm	180	1595	F07	14mm
4"	100	230	2036	F07	14mm	260	2300	F07	17mm
5"	125	250	2212	F10	17mm	380	3363	F10	17mm
6"	150	300	2655	F10	17mm	525	4646	F10	22mm
8"	200	410	3629	F12	22mm	1040	9200	F12	27mm
10"	250	630	5576	F12	22mm	1990	17610	F12	27mm
12"	300	1130	10001	F14	27mm	3125	27660	F14	34mm
14"	350	1740	15400	F14	27mm	4600	40710	F14	36mm
16"	400	2810	24870	F16	34mm	6950	61510	F16	40mm
18"	450	3180	28145	F16	40mm	8750	77444	F16	46mm
20"	500	5500	48680	F25	46mm	13000	115060	F25	50mm
24"	600	7350	65052	F25	φ 70	20750	Consult	F30	φ 90

Notes: \*Other sizes & pressures are available upon request.

\*Torque value excluded safety factor for reference.

\*Up to 20", shaft ends in square type, 24" and above valves' shaft in round type.

**MODEL:**

**BWT150/BWT300**  
**BLT150/BLT300**

\* CF-Consult Factory for Larger Sizes.

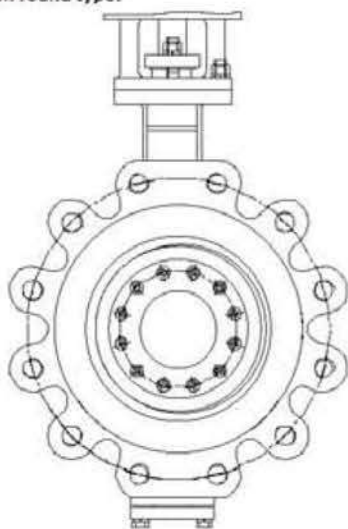

Bare shaft

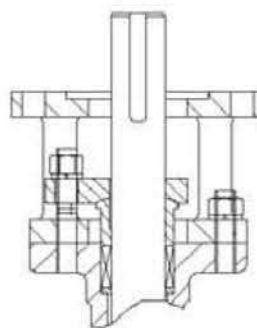

Triple offset butterfly valve

Top flange (ISO 5211)

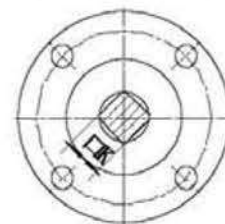

Square type

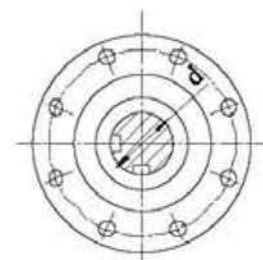

Round type

Due to continuous development & improvement of our Product range, we reserve the right to alter the dimensions & technical data included in this brochure.



# PRODUCT FIELD

## Petroleum Industry

The petroleum industry, also known as the oil industry or the oil patch, includes the global processes of exploration, extraction, refining, transporting (often by oil tankers and pipelines), and marketing manufacturing of petroleum products. MSI designed duplex, ali, bronze, and titanium valves are ideal products for the downstream and upstream pipe requirements.

## Coal Chemistry

Coal Chemistry includes coal coking, gasification, liquification, coal refinery, and etc. MSI designed valves are often used for coal coking and gasification.

## Organic Chemistry

An organic compound is virtually any chemical compound that contains carbon, although a consensus definition remains elusive and likely arbitrary. Max-Seal valves perform outstandingly on such applications as acetic acid, PTA, alkylation, cyclohexanone, BDO, and sec-butyl acetate.

## Inorganic Chemistry

Inorganic chemistry deals with the synthesis and behavior of inorganic and organometallic compounds. This field covers all chemical compounds except the myriad organic compounds (carbon based compounds, usually containing C-H bonds), which are the subjects of organic chemistry.

## New Energy

Due to rapid world growth, energy consumption is increasing. Also energy supply and the demand gap is increasing as well. Therefore, development of new energy becomes the main subjects for all around the world. New energy is based on new technology, system development, and utilization of renewable energy, such as nuclear energy, solar energy, ocean energy and so on.

## Environment Water Treatment

Water treatment is any process that makes water more acceptable for a specific end use. The end use may be drinking, industrial water supply, irrigation, river flow maintenance, water recreation, or many other uses, including being safely returned to the environment. Water treatment removes contaminants and undesirable components or reduces their concentration so that the water becomes fit for its desired end use.

### **TSI: ChemLite Plus (LIBS)**

*ChemLite Plus is TSI's newest handheld LIBS metals analyser. Units are designed to be accurate and fast, with one to two second readings and eye-safe, Class 1M lasers. Because there's no radiation, there are no regulation requirements. Compared to XRF units, ChemLite is easy and safe for any operator. Additionally, ChemLite analysers have the largest laser spot size available, and a built-in cleaning mode. ChemLite guns identify Al, Mg, Ti, Fe, Ni, and Cu alloys, and are able to separate close Al alloys that XRF cannot. TSI LIBS technology can also detect tramp elements, like Li and Be, down to 1 ppm and can measure copper alloys.*



### **Special Testing**

Available for all alloys consult factory for additional information.





# BUTTERFLY VALVES *Special Alloys*

EXOTIC ALLOY MATERIAL SERIES				
Common	Forging	Casting	Service Application	
Designation	Spec	Spec		
ID CODES				
Alloy 20	A20	B462 N08020	A351 CN7M	An austenitic stainless for sulfuric acid corrosion environments. Resists intergranular corrosion as welded. Resistant to chloride and polythionic acid stress corrosion cracking.
Titanium Gr.2	T02	B381 Gr. F-2	B367 Gr. C-2	Good resistance to corrosion together with low specific weight. Widely applied in the chlor-alkali industry, soda industry, the pharmaceutical industry, fertilizer industry, nitric acid industry fields etc. Best choose for paper and pulp application.
Titanium Gr.3	TI3	B381 Gr. F-3	B367 Gr. C-3	
Titanium Gr.5	TI5	B381 Gr. F-5	B367 Gr. C-5	
Titanium Gr.6	TI6	B381 Gr. F-6	B367 Gr. C-6	
Titanium Gr.12	T12	B381 Gr. F-12	B367 Gr. C-12	
Titanium Pd7B	TI8	B381 Gr. F-7	B367 Pd7B	
Nickel 200	N20	B160 N02200	A494 CZ100	
Nickel 201	N21	B160 N02201		
Monel 400	M40	B564 N04400	A494 M35-1/ M35-C	For corrosive service such as acids, alkalies, salt solutions.
Monel K500	M50	B865 N05500		Mainly used in hydrogen fluoride gas and hydrofluoric acid solution condition.
Inconel 600	I60	B564 N06600	A494 CY40	For high temperature service, used for nuclear applications.
Inconel 625	I62	B564 N06625	A494 CW6MC	
Incoloy 800	I80	B564 N08800	A351 CT15C	
Incoloy 825	I82	B564 N08825	A494 CU5MCuC	
Hastelloy B	HB1	B335 N10001	A494 N12MV	Hastelloy super alloys are effective under high-temperature, high-stress service in a moderately to severely corrosive, and/or erosion-prone environment where more common and less expensive iron-based alloys would fail. This includes the pressure vessels of some nuclear reactors, chemical reactors, distillation equipment, and pipes and valves in the chemical industry.
Hastelloy B-2	HB2	B462 N10665	A494 N7M	
Hastelloy C276	HC6	B564 N10276	A494 CW12MW/ CW6M	
Hastelloy C-22	HC2	B564 N06022	A494 CX2MW	
Hastelloy C-4	HC4	B574 N06455	A494 CW2M	
Hastelloy G	HLG	B462 N06007		
Hastelloy G30	HG3	B462 N06030		
Zirconium 702	Z02	B493 R60702	B752 702C	Outstanding corrosion resistance to hydrochloric acid, sulfuric acid, acetic acid, applicable for any density alkaline solution.
Zirconium 705	Z05	B493 R60705	B752 705C	

*Due to continuous development & improvement of our product range, we reserve the right to alter the dimensions & technical data included in this brochure.*



# **INTERNATIONAL VALVE** **TECHNOLOGIES**

**One Source Where Great Valves and Brands Unite!**



**Max-Seal offers a Complete Automation Package of Pneumatic, Hydraulic & Electric Actuators as well as Accessories.**

———— We Also Offer The Following ————  
———— Valve Types in Special Alloys. ————



**Knife Gate**



**Globe/Gate**



**Check**



**Plug**



4815 West 5th Street  
Lumberton N.C. 28358

[www.maxsealinc.com](http://www.maxsealinc.com)

PH: 910-738-2866  
FAX: 910-739-1733

Revision No: 501-22\_v01  
Last Review/Update: 03/16/22