

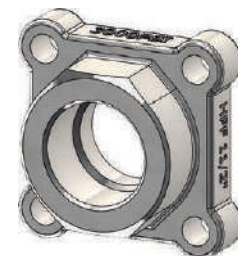

HPF-3000 Series

HPF-3000 is a variant of the standard Tri-Pro Series. The burst pressure of these valves is approx. 4500psi based on hydro-testing conducted in the past in our facility and a third party testing lab.

- 3000 psi working pressure requirements
- The wall thickness of NPT Endcaps meet ASME B16.34 Class 1500 design specification.
- Socket-Weld Ends are now upgraded to SCH160.
- Bolting is being upgraded from A2-70 (tensile strength = 700MPa and yield strength - 450MPa) to A4-80 that has better tensile strength of 800MPa and a yield strength of 600MPa. This will allow for a robust body-endcap joint clamping strength.
- Length of Endcap will be 1/4" more on NPT variant, so the overall face to face dimension of valve assembly will increase by 1/2". Socket weld ends will remain the same as standard.
- HPF-3000 Series is certified for 3000psi maximum allowable working pressure (MAWP) at ambient temperature.
- NPT Endcap will have a slightly unique design this time as shown below



The part numbering system of this series will be as follows:

- HPF61** – NPT Carbon Steel
- HPF71** – Stainless Steel
- HPF62** – SW Carbon Steel
- HPF72** – SW Stainless Steel

Torque Values

in-lbf	size
174	0.5
226	0.75
269	1
391	1.25
712	1.5



Bill of Materials

Item	Parts	Qty	Stainless Steel	Carbon Steel
1	Body	1	ASTM-A351-CF8M	ASTM-A216-WCB
2	Caps	2	ASTM-A351-CF8M	ASTM-A216-WCB
3	Ball	1	ASTM-A351-CF8M	ASTM-A351-CF8
4	Seats	2	TFM/ 50% Stainless Filled PTFE/CTFM	TFM/ 50% Stainless Filled PTFE/CTFM
5	Outer Gaskets	2	Graphite	Graphite
6	Inner Gaskets	2	TFM/Graphite	TFM/Graphite
7	Stem	1	ASTM 17-4 PH	ASTM 17-4 PH
8	Thrust Bearing	1	50%316+PTFE	50%316+PTFE
9	Thrust Washer	0~1	50%316+PTFE	50%316+PTFE
11	Stem Packing	2~3	Graphite	Graphite
12	Packing Follower	1	AISI 304	AISI 304
13	Belleville Washers	2	AISI 304	AISI 304
14	Stop Pin	1	AISI 304	AISI 304
15	Stem Nuts	2	AISI 304	AISI 304
16	Handle	1	AISI 430	AISI 430
17	Plastic Cover	1	Plastic	Plastic
18	Lock Washer	1	AISI 304	AISI 304
19	Bolts	8	A4-80	A4-80

A4-80 generally means the bolt is from 316SS grade and has an ultimate tensile strength of 80kg or 800n/mm2.

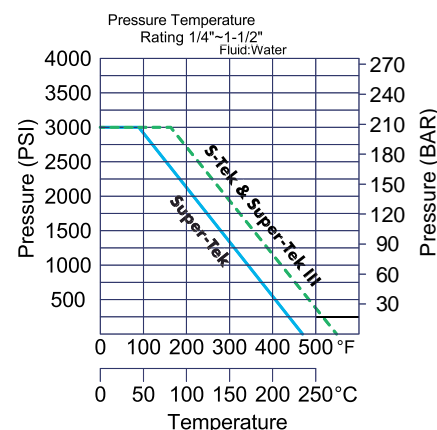
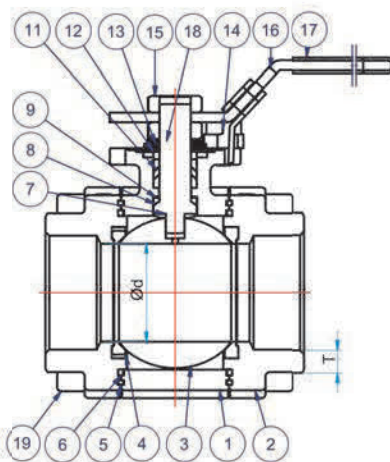
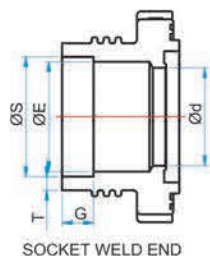
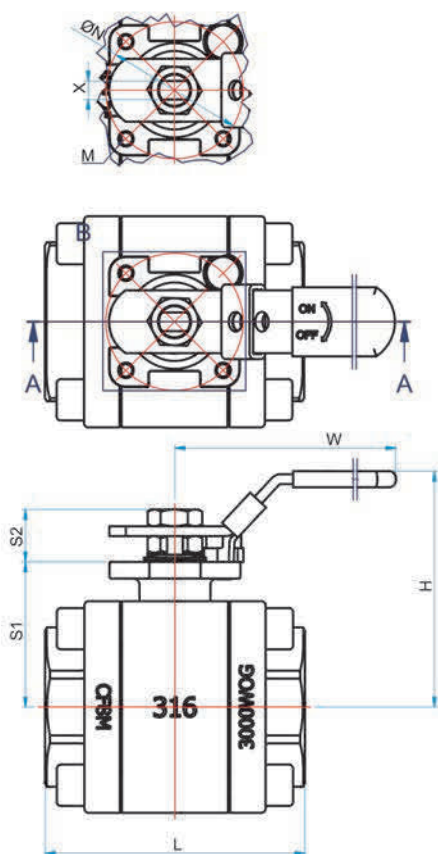

Size	Ød	NPT-L	SW-L	H	W	S1	S2	ØS	ØE	ØF	G	ØN	M	X	T
1/4"	0.46	3.22	4.81	2.69	6.3	1.54	0.53	0.56	0.91	1.03	0.39	1.65	#10-24UNC	0.25	0.16
3/8"	0.5	3.22	4.81	2.69	6.3	1.54	0.53	0.69	0.91	1.03	0.39	1.65	#10-24UNC	0.25	0.17
1/2"	0.59	3.41	4.89	2.69	6.3	1.54	0.53	0.86	1.1	1.28	0.39	1.65	#10-24UNC	0.25	0.21
3/4"	0.79	3.89	5.17	2.85	6.3	1.7	0.53	1.07	1.38	1.56	0.51	1.65	#10-24UNC	0.25	0.24
1"	0.98	4.2	5.24	3.44	6.89	2.06	0.74	1.33	1.56	1.88	0.51	1.97	1/4-20UNC	0.31	0.27
1 1/4"	1.26	4.59	5.72	3.57	6.89	2.19	0.74	1.68	1.97	2.32	0.51	1.97	1/4-20UNC	0.31	0.32
1 1/2"	1.57	5.11	6.19	4.24	8.66	2.65	0.88	1.92	2.2	2.62	0.51	2.76	5/16-18UNC	0.37	0.35

For Torque and other details refer to Tri-Pro Tech Bulletin 51